

## WARPING MILL

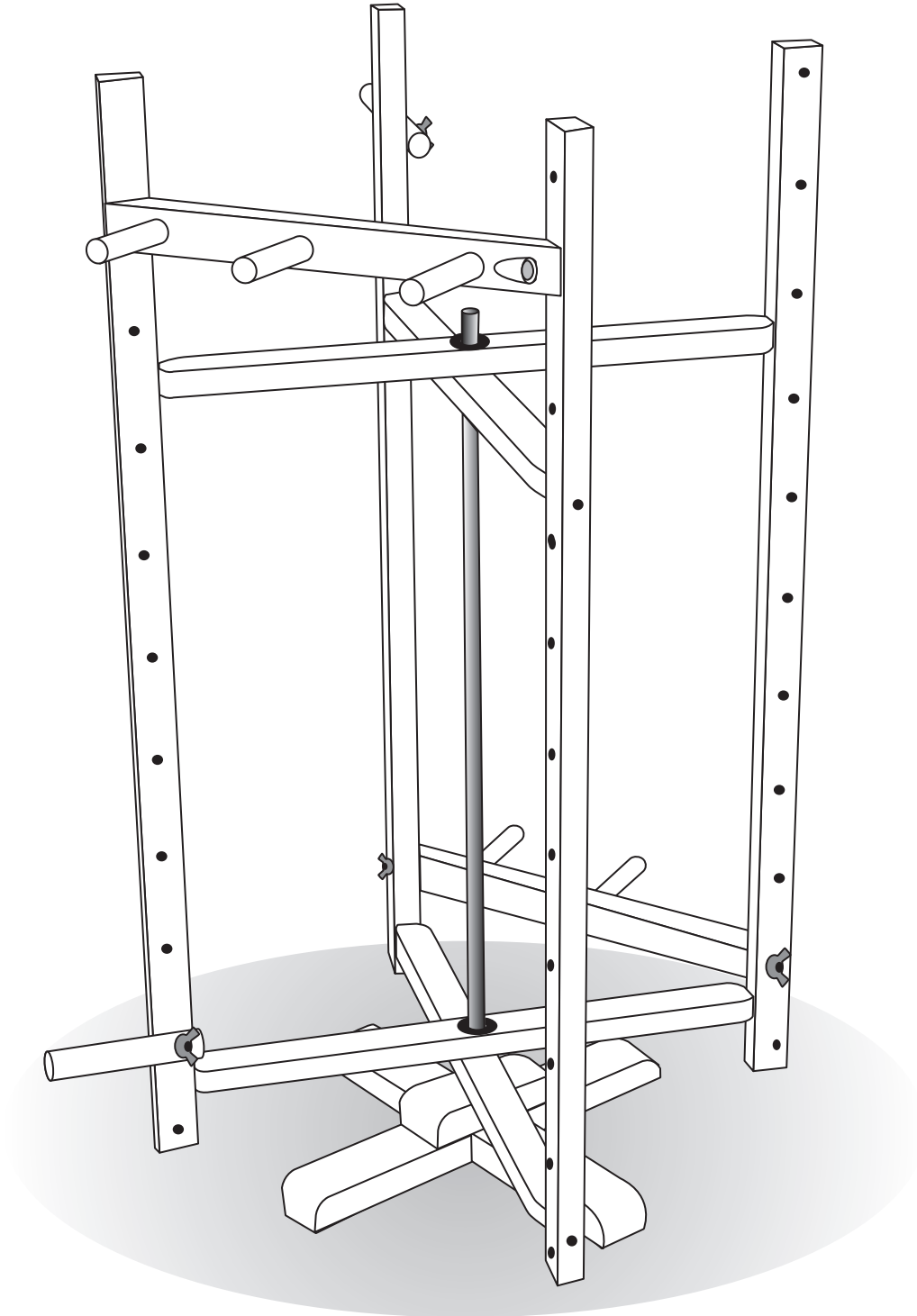

WM260724

### Ashford Guarantee

Thank you for purchasing this Ashford product. In the unlikely event of a fault in manufacture, please contact the dealer you purchased it from.

### Ashford Blog

For inspirational articles, patterns and projects. Subscribe for free [www.ashford.co.nz/blog](http://www.ashford.co.nz/blog)

**Parts List**

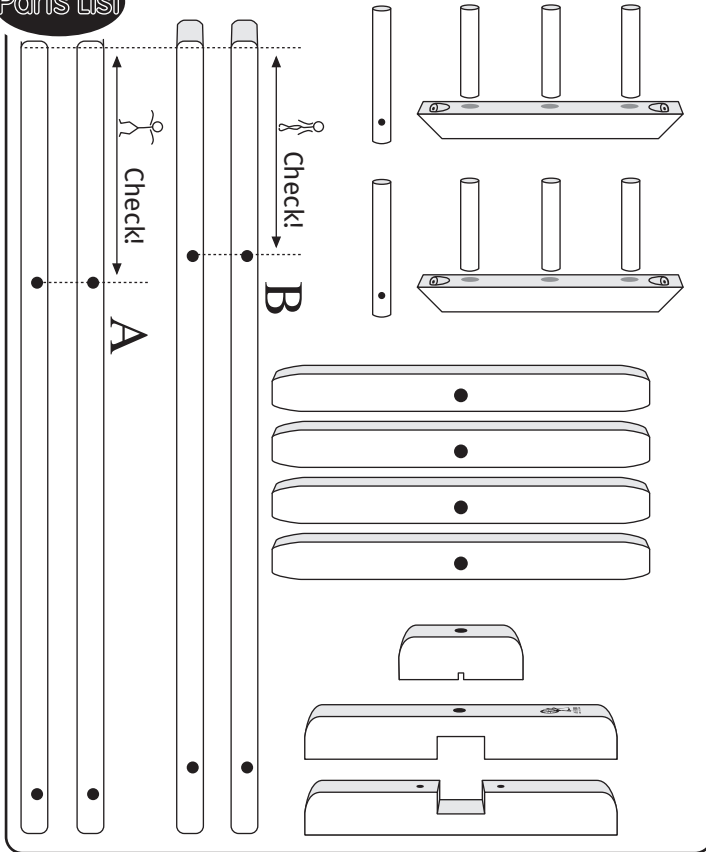

**TOOLS**

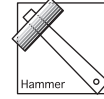

**Hint**

To make assembly easier use candle wax on the screws.

Hard

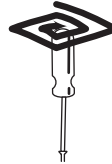

Easy



**Hardware List**

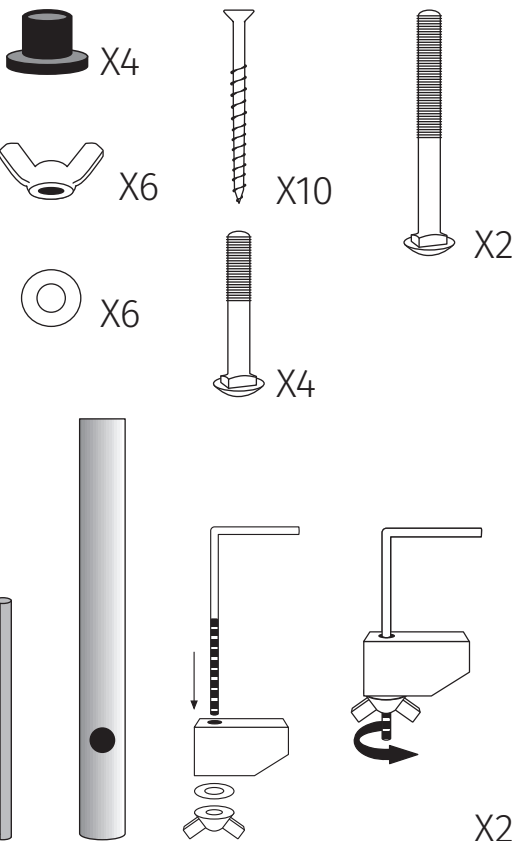

**Before Commencing**

Read the instructions completely, identify the parts and note the assembly sequence. Then use the fine sandpaper supplied to remove any sharp corners or edges.

**Finishing the Wood**

We recommend that the wood surfaces be waxed before assembly. This protects the kiln dried wood from climatic changes and enhances the beauty of the wood. Avoid waxing the dowel ends or holes.

**For the Ultimate Finish**

Ashford Finishing Wax Polish will enhance the natural colours and beauty of the beech timber which has a lovely variety of colour and grain.

Step 1

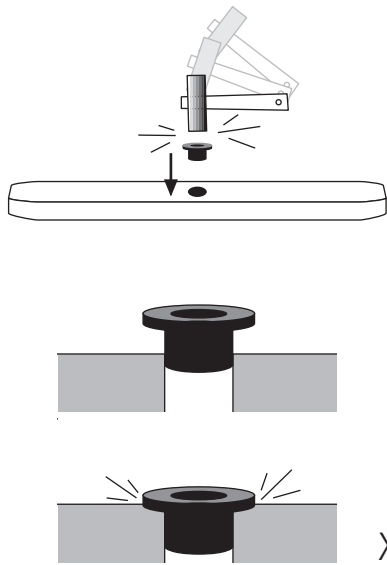

X4

Step 2

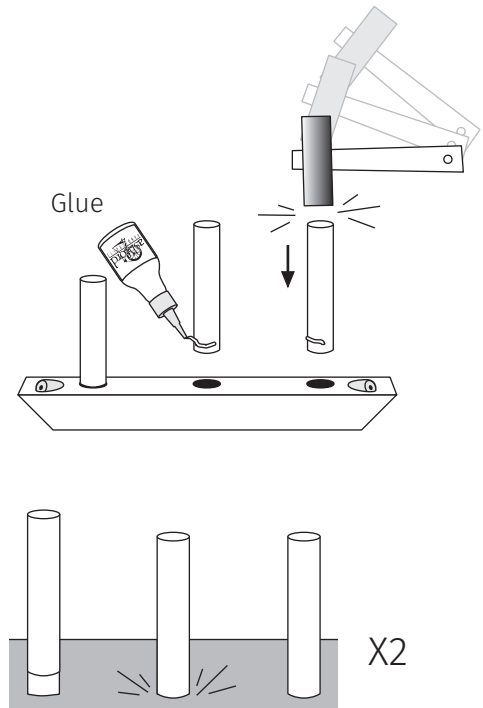

X2

Step 3

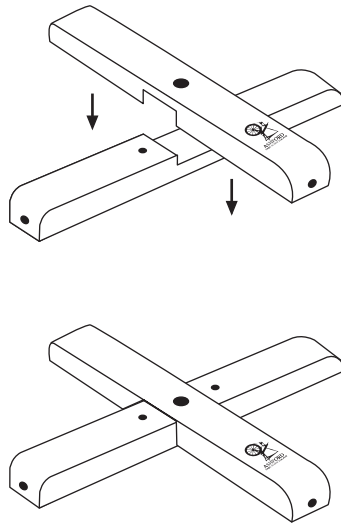

Step 4

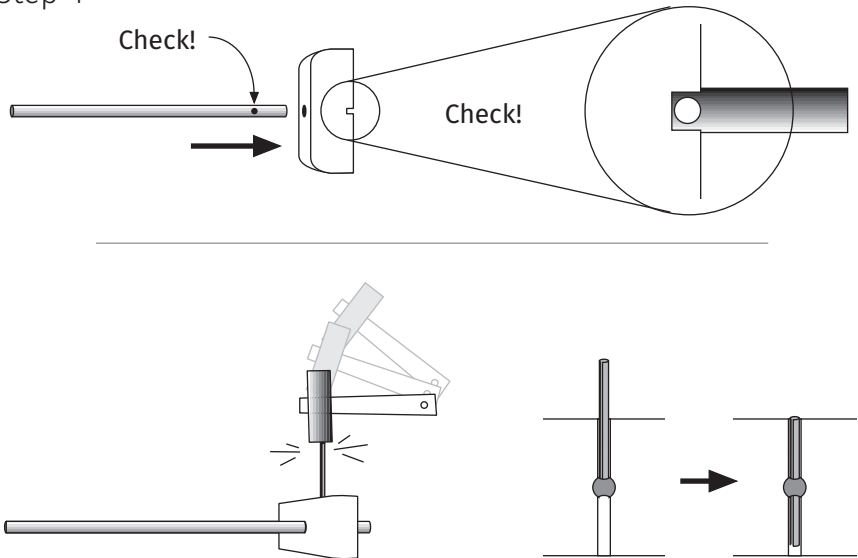

Step 5

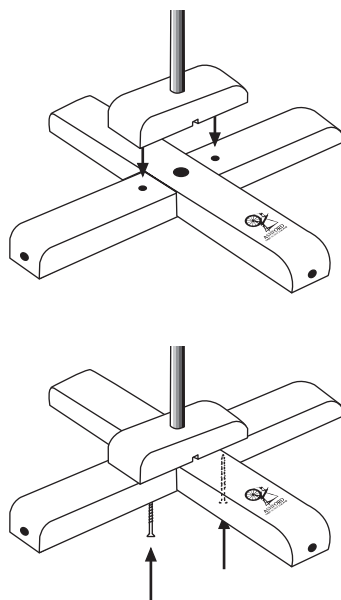

Step 6

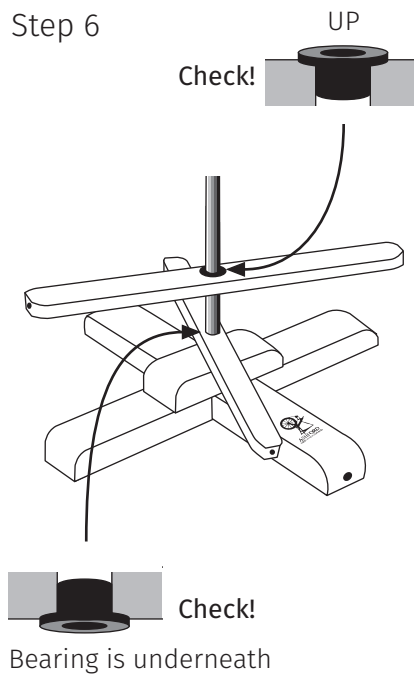

Step 7

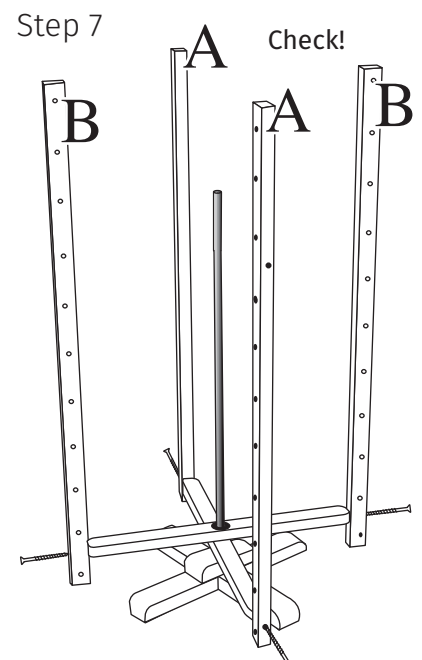

Step 8

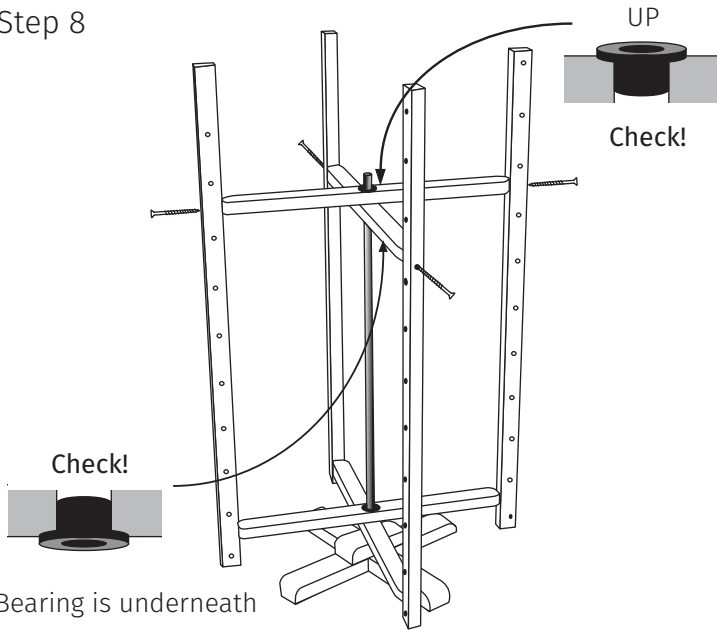

Step 9

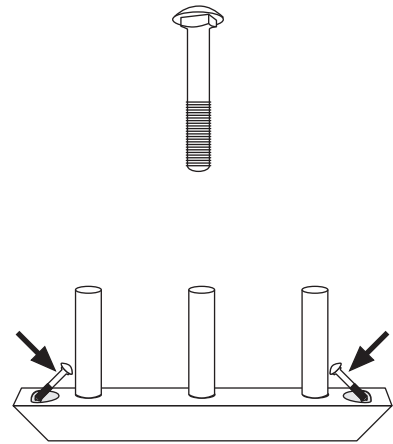

Step 10

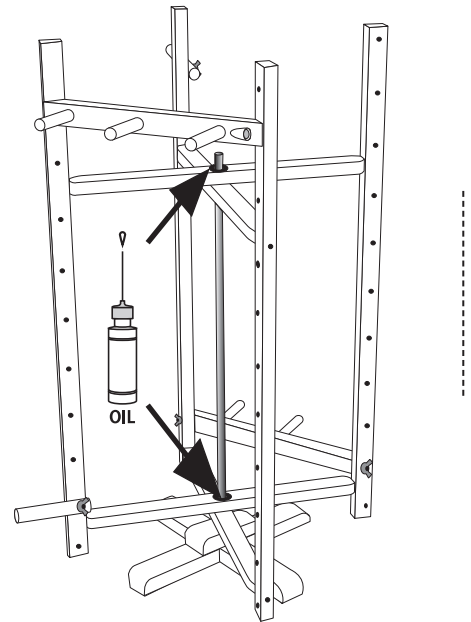
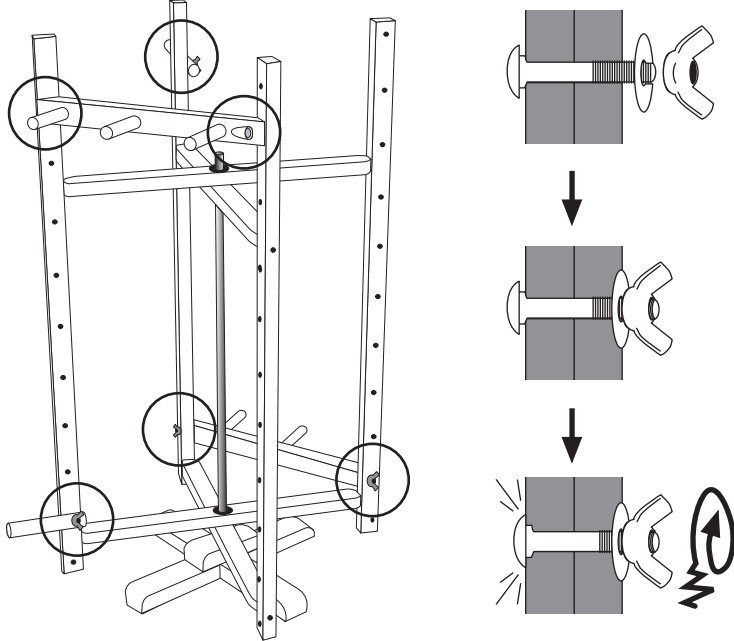

\*Apply a drop of oil as required.

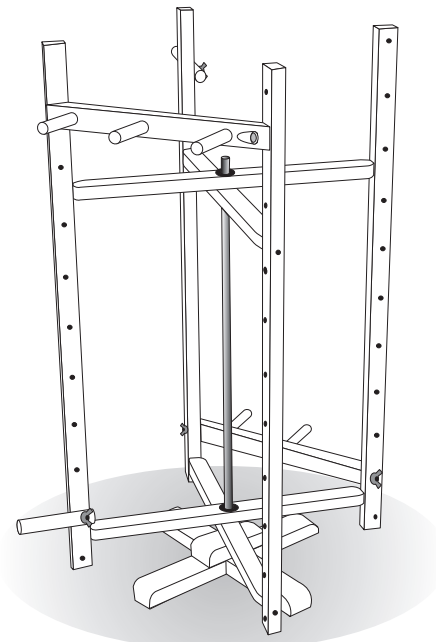
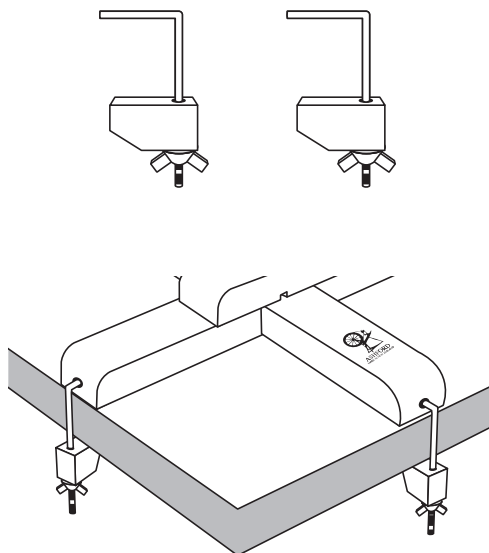

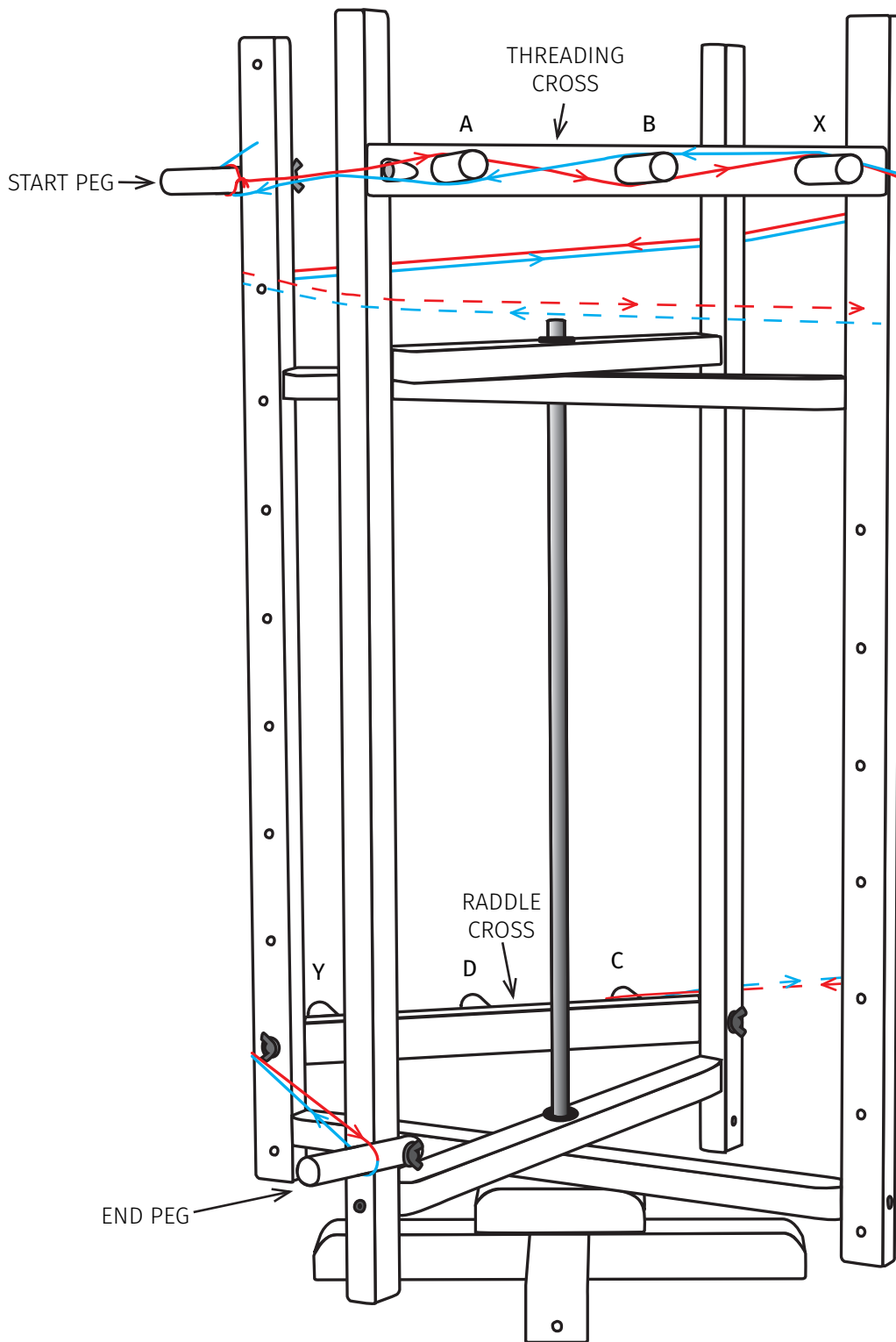

Continue winding around the warping mill. Use a length of string as a warp length guide.  
*See photo on following page.*

### CROSSES

For fuss-free warping, you will make two crosses.

**The first cross** between pegs A and B, is the threading cross which keeps the yarn in the correct order for threading. Each thread is separated at the cross.

**The second cross** between pegs C and D is the raddle or counting cross.

**Example:** The Ashford raddle has half inch (12.5mm) spacings. If your project has a sett of 20 dpi you will make the raddle cross after each group of 10 threads.

### WINDING THE WARP

1. Clamp the warping mill to a table.
2. Measure a length of string the required length of the warp. This will be your warping guide. Tie a loop and place on the start peg, Take the string over peg A and under peg B, then over peg X. Spin the mill to wrap the

string around and down to the end of the warp string length. Finally take the string over C, under D and tie it to the end peg.

3. Place the yarn at the base of your feet and begin winding your warp following the guide yarn, remembering to take the yarn over A and under B (when returning pass the yarn over B and under A). This makes the threading cross. It is important for the yarn to have even tension.
4. Take the yarn over C, under D and around the end peg. In this example the raddle cross is in groups of 10. Return under D and over C for 10 threads (5 return trips). The eleventh thread will go under C, over D, around the end peg, back over D and under C.

**Note:** All threads must pass over collection peg X and under collection peg Y.



The threading cross - each thread is crossed.



The raddle cross - threads in groups of 10 crossed.

## More Information



**How-to videos on You Tube**  
Watch our how-to videos on You Tube.  
@AshfordNZ



**Facebook**  
Join us on facebook ashford.wheels.looms



**Blog**  
For inspirational articles, patterns and projects. Subscribe for free to the Ashford Blog [www.ashford.co.nz/blog](http://www.ashford.co.nz/blog)

For helpful hints and inspiration we recommend the *Learn to Weave on the Table Loom* booklet and *The Ashford Book of Weaving Patterns from Four to Eight Shafts* by Elsa Krogh.