

SKEINER 2

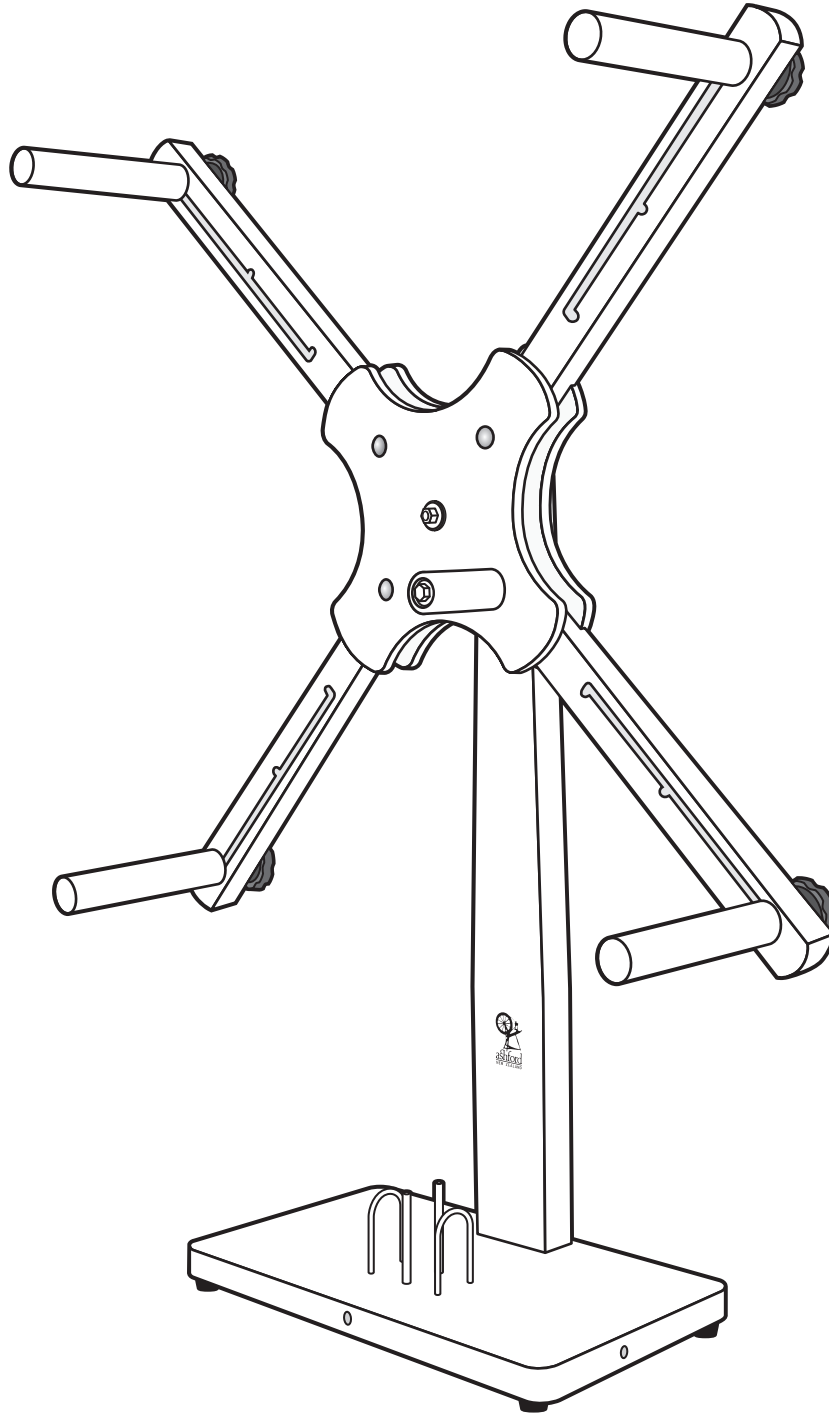

SK2-040624

Ashford Guarantee

Thank you for purchasing this Ashford product. In the unlikely event of a fault in manufacture, please contact the dealer you purchased it from.

Ashford Blog

For inspirational articles, patterns and projects. Subscribe for free www.ashford.co.nz/blog

ASSEMBLY INSTRUCTIONS FOR THE ASHFORD SKEINER 2

Before commencing, please read these instructions completely, identify the parts and note the assembly sequence.

The Beech timber has a lovely variety of colour and grain. This skein holder has been finished with a water based lacquer to protect the kiln dried timber from climatic changes and enhance its natural character. To repair and restore the finish use Ashford Finishing Wax Polish.

Tools Required

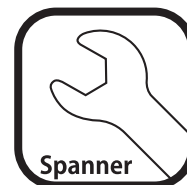

(included)



More Information



How-to videos on You Tube

Watch our how-to videos on You Tube @AshfordNZ



Facebook

Join us on facebook ashford.wheels.ooms



Blog

For inspirational articles, patterns and projects. Subscribe for free to the Ashford Blog www.ashford.co.nz/blog

Hints

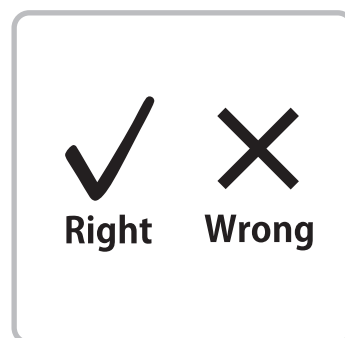
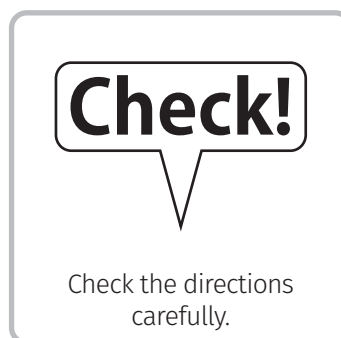
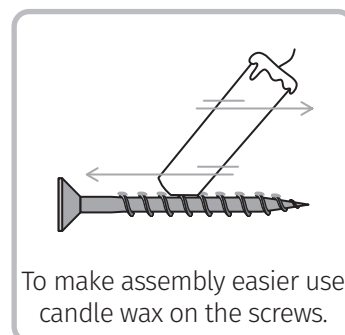
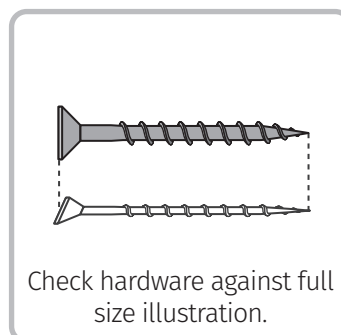

Attach the 4 rubber feet to the underside of the base with small screws.

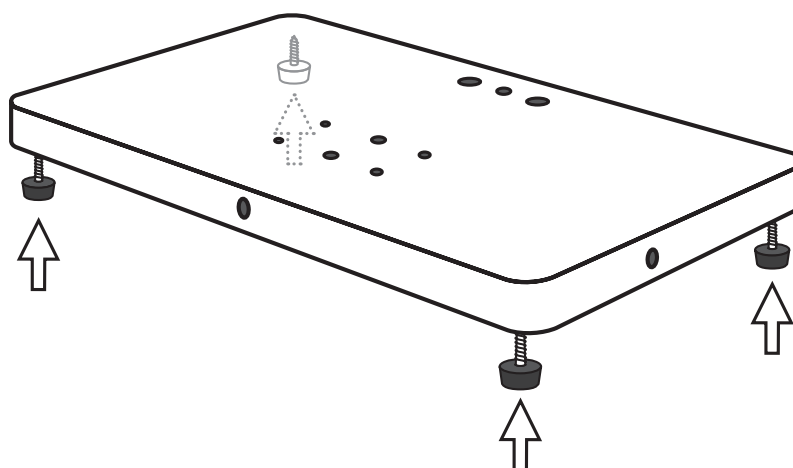
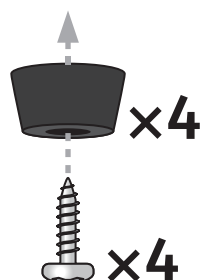

2

Squeeze the ends of the U shape yarn guides together and locate them into the small holes in the base. Gently tap in if necessary.

Locate the 2 yarn tension pins into the large holes in the base and gently tap in.

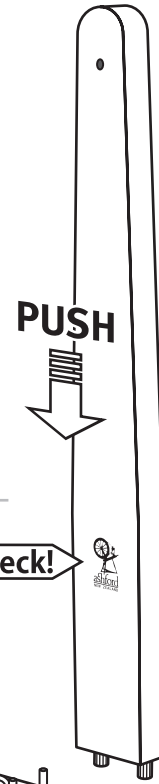
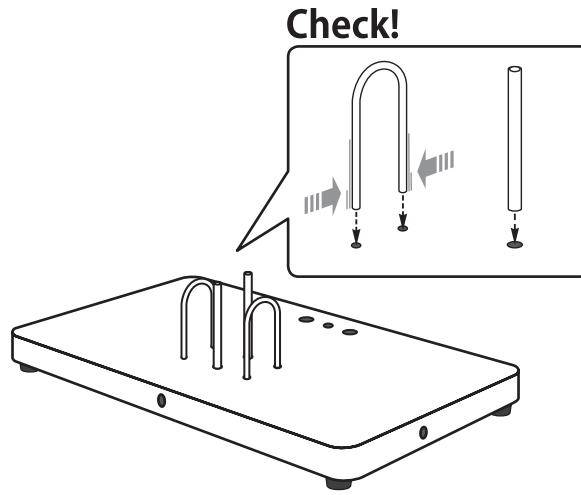

3



Tap the 2 wooden dowels into the main upright.

Push the wooden dowels in the main upright into the holes in the base.



x2

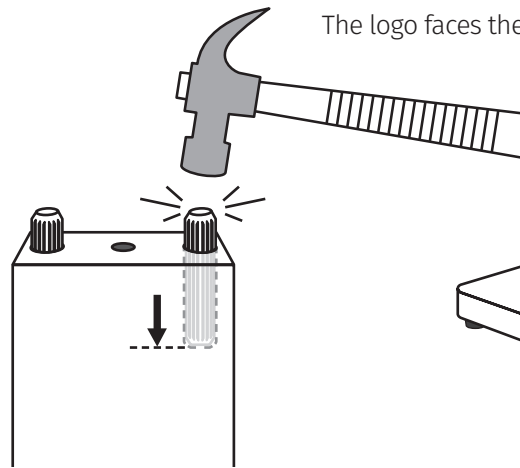

4



Insert the barrel nut into the main upright. Fit a large washer to the 65mm (2½") bolt. Locate it into the base and main upright and secure with a barrel nut. Tighten firmly with a spanner.

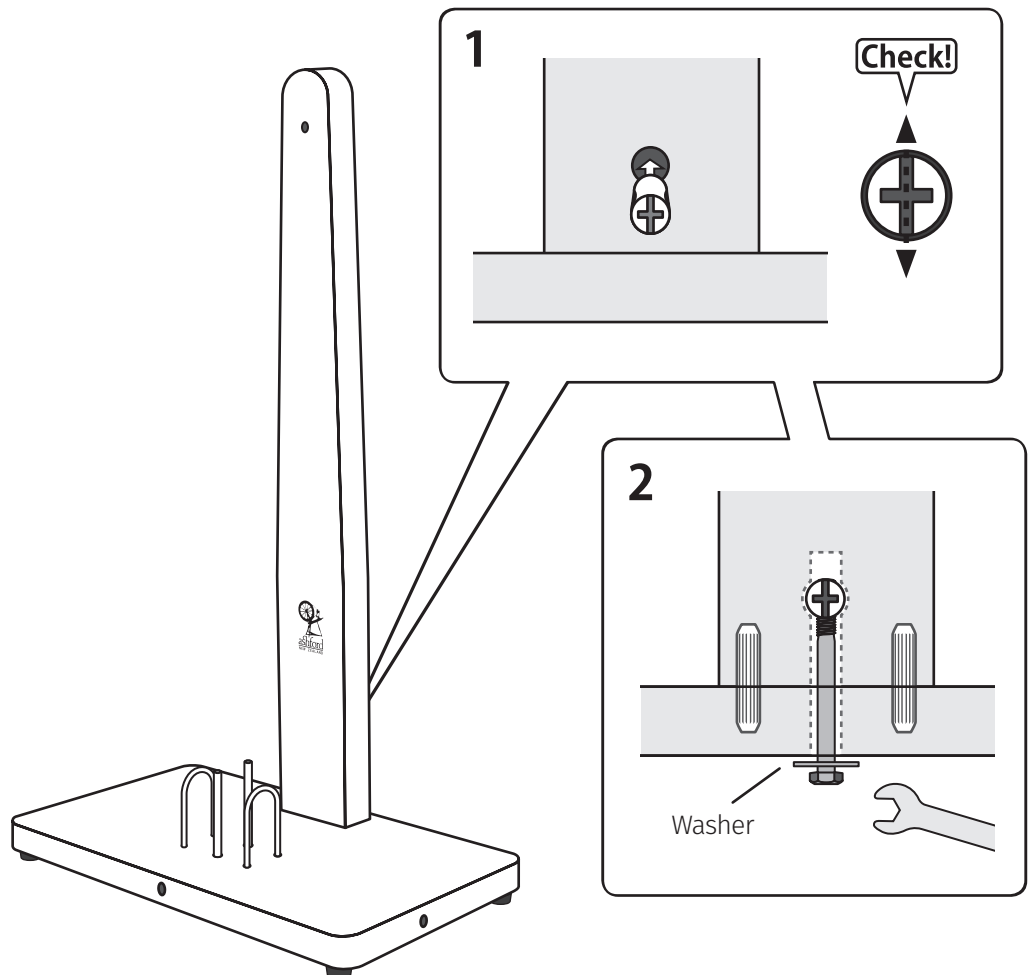
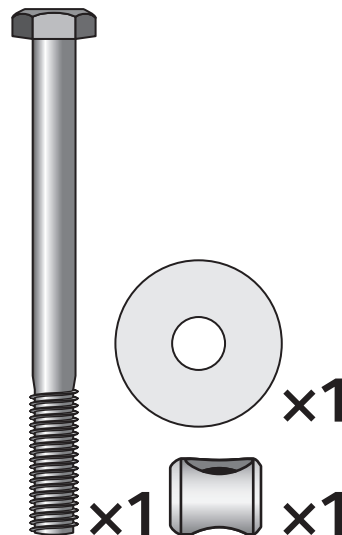

5

Press the 2 nylon bearings into the centre holes in the 2 arm-supports keeping the flange to the outside.

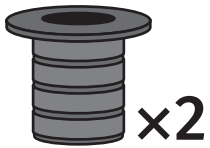
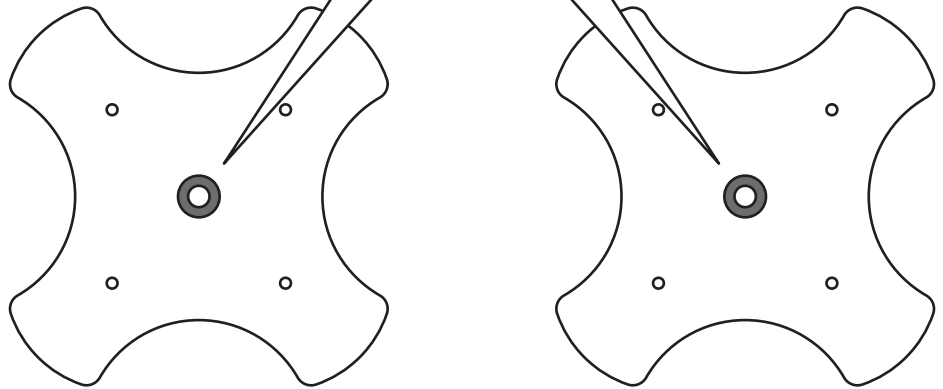
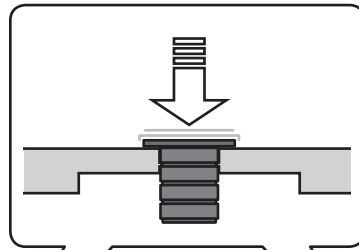

6

Align the hole in one arm with the hole in one arm-support and then push into the groove.

Check!



Align the holes.

1

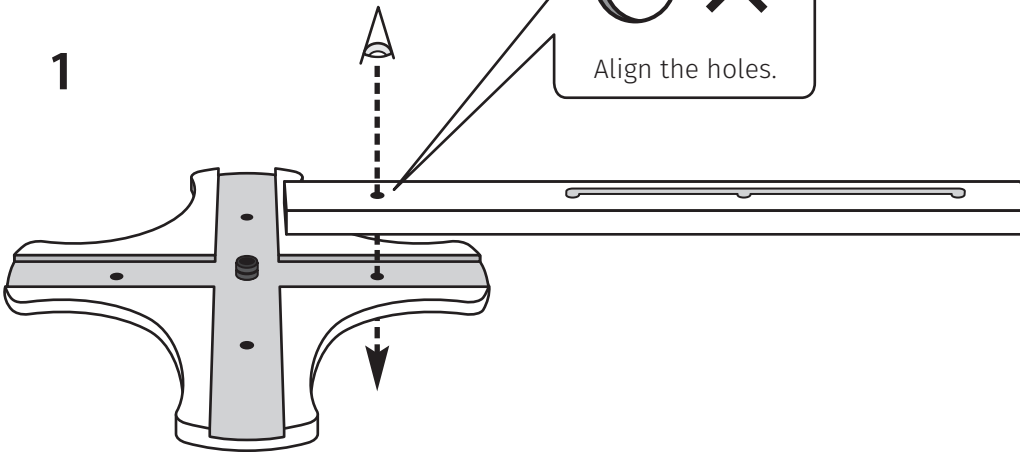

2

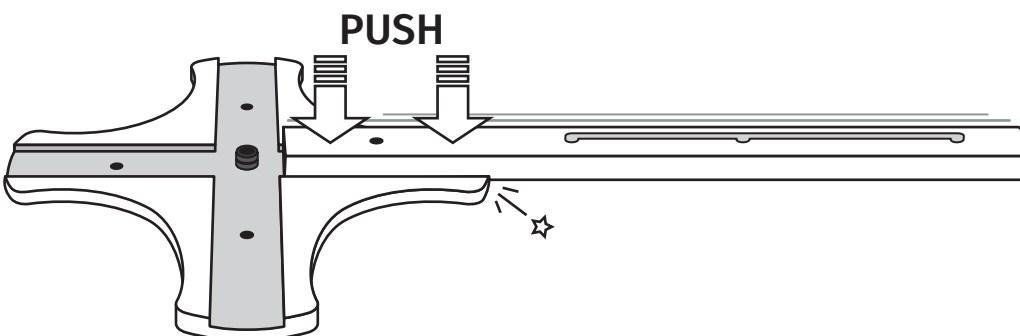

Note

Repeat for all arms with the position stops all in one direction.

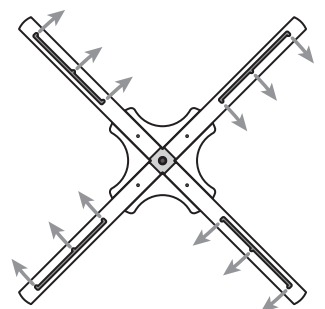
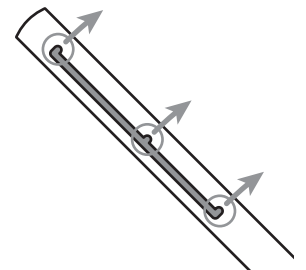

7

Locate the other arm-support on top of the arms. Push 3 x 40mm (1 5/8") round head bolts through the holes in the arm-supports and arms. Fit small washers and nuts but don't tighten yet.

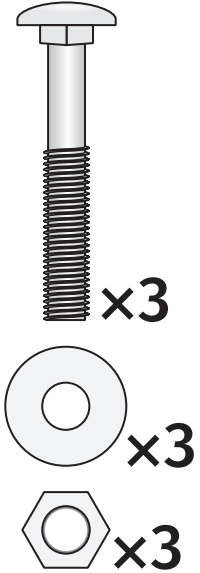
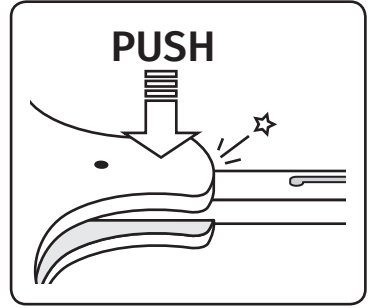
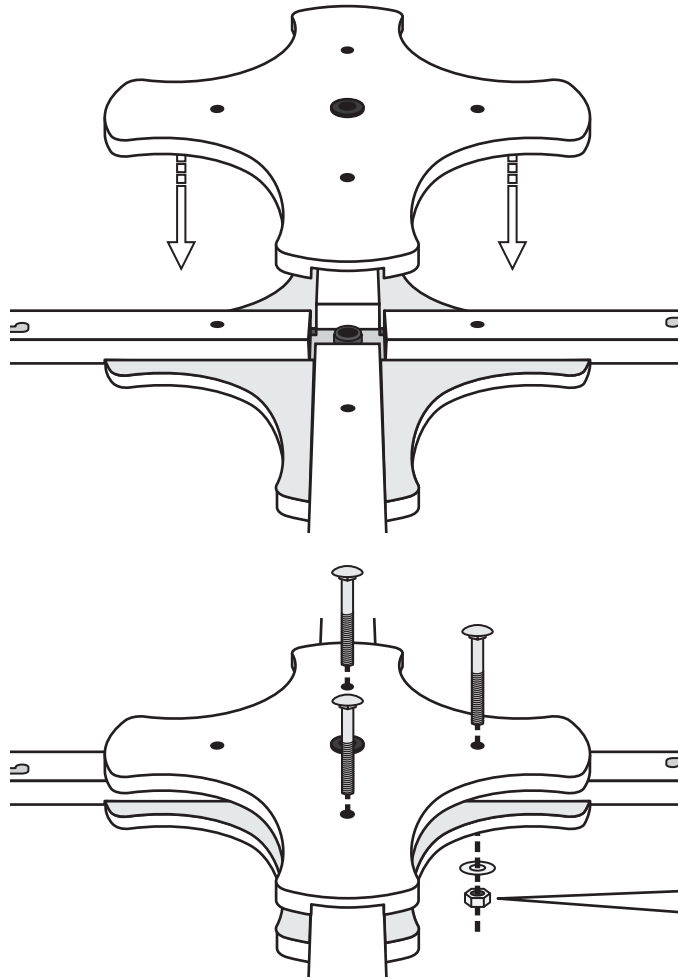

Check!

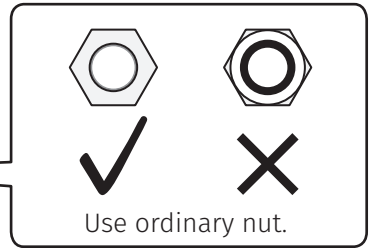

8



Fit a small washer followed by the long 58mm (2 1/4") aluminium spacer to the 100mm (4") bolt. Apply a drop of oil to the spacer. Then slide the wooden handle onto the bolt so the head of the bolt is at the counter-bored end. Fit another small washer and push the bolt through the arm-support and arm from the same side as the other bolts. Secure with a small washer and nylock nut. Tighten with the 2 spanners supplied. Then tighten all nuts.

Check!

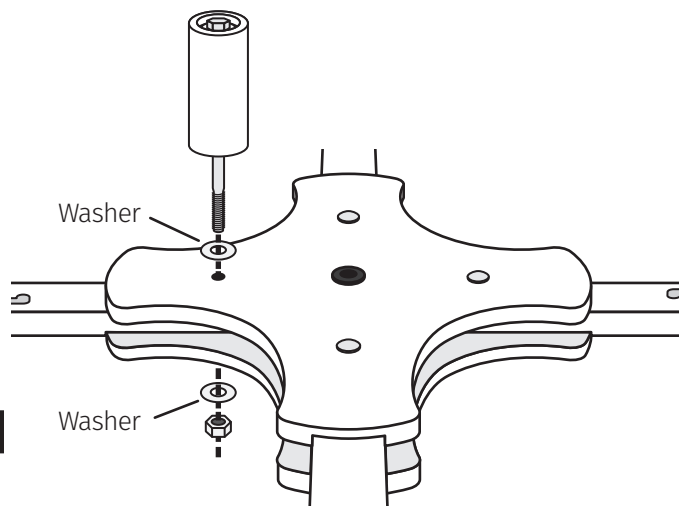
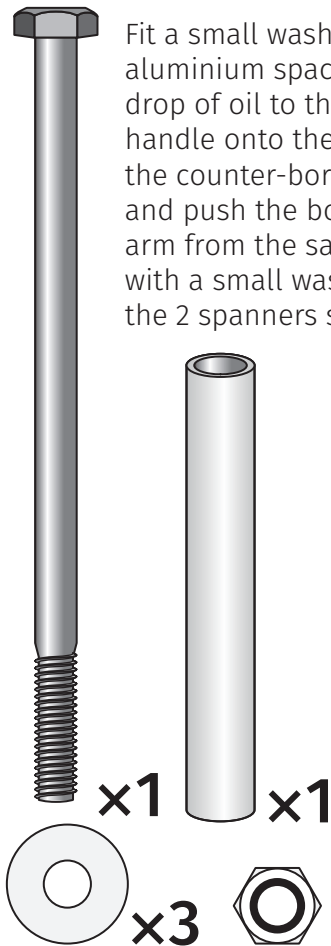
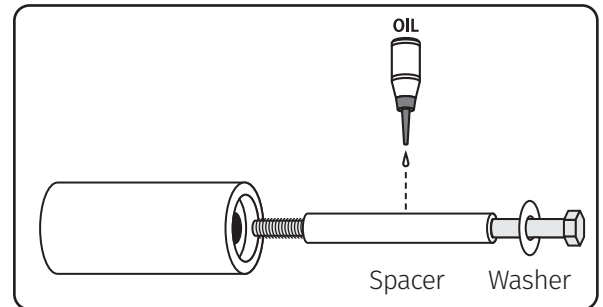

Check!

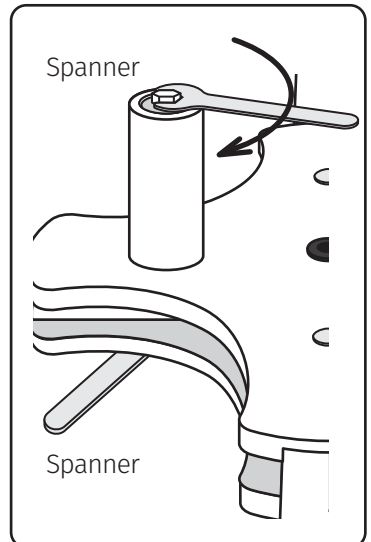

9 

Fit a large washer onto the 100mm (4") bolt and push it through the main upright from the back. Locate the wooden spacer onto the bolt followed by a large washer and 37mm (1 7/16") aluminium spacer. Apply a drop of oil to the spacer.

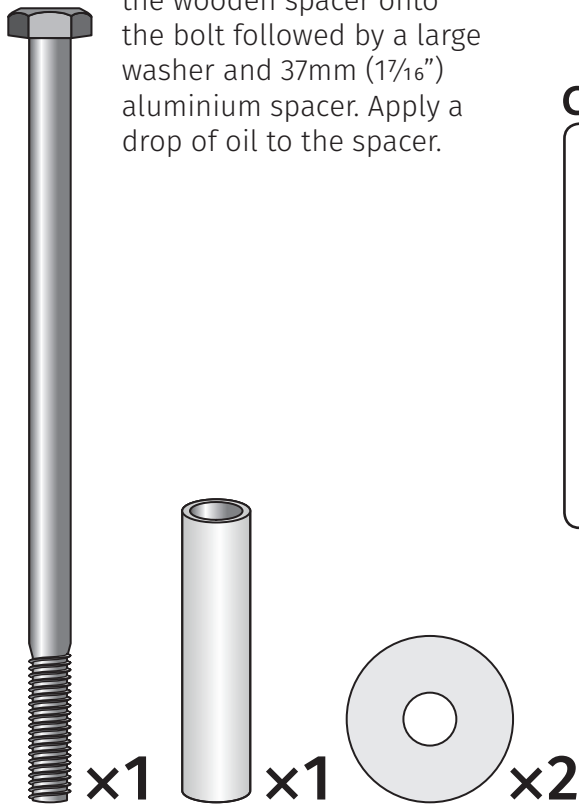

Check!

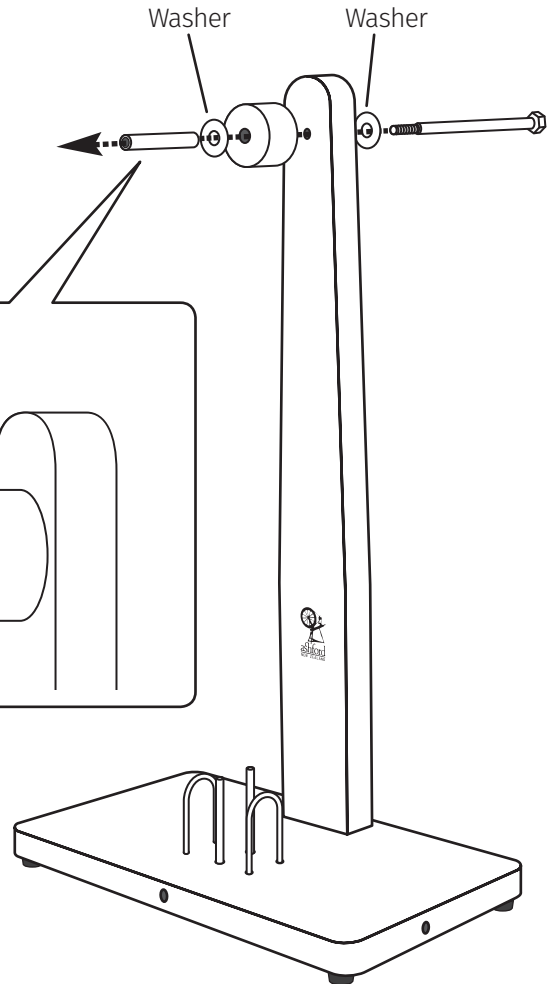
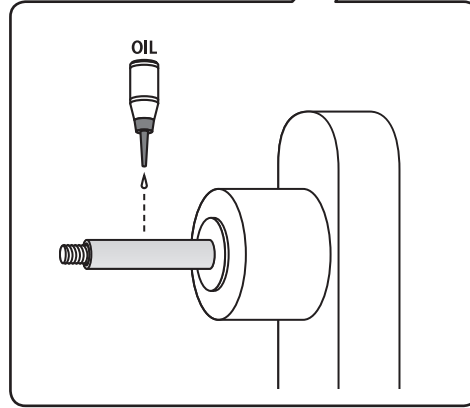

10 

Then slide the arm assembly onto the aluminium spacer followed by a small washer and nylock nut. Tighten firmly with 2 spanners.

Check!

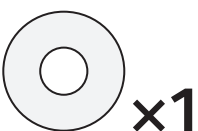
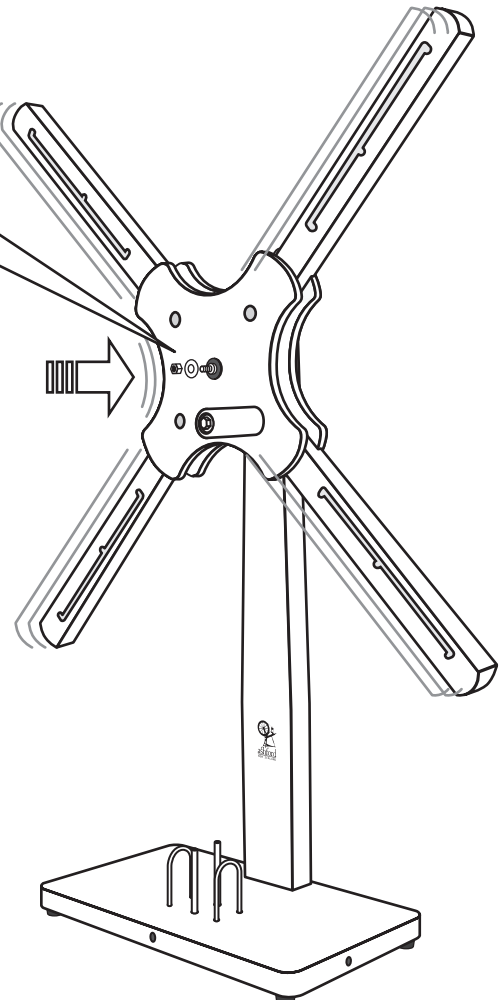
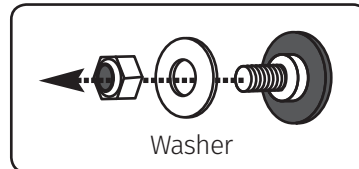

11



Locate the metal threads in the 4 pegs through the slots in the arms and secure with large washers and knobs.

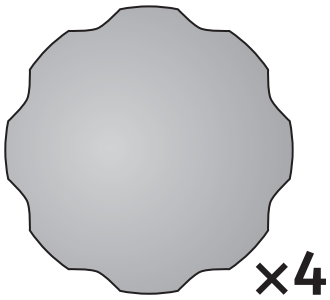
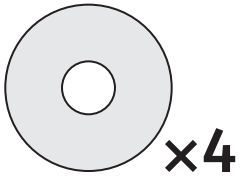
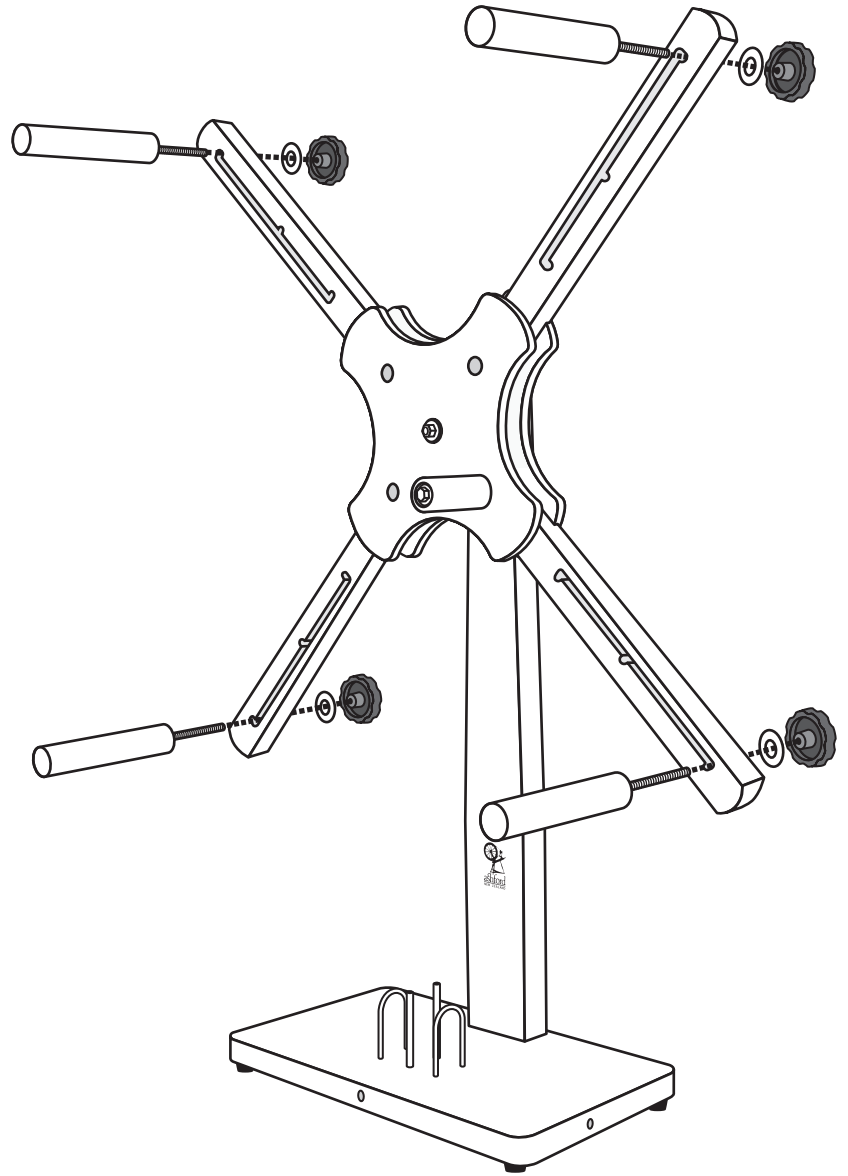

Note

The position stops in the grooves indicate specific length skeins.

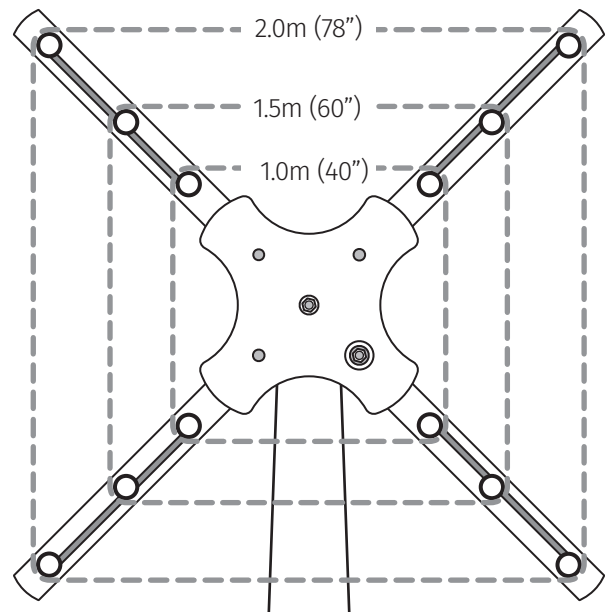
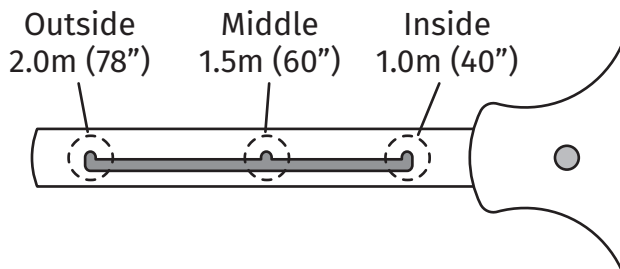

Skeins of a variety of lengths can be made by adjusting the pegs or using 3 pegs.

Your skein holder is now ready for use.

When completed, tie you skein between each arm to prevent it tangling.

To remove skeins from the skein holder, loosen one peg and slide it inwards.

Assemble and use the clamp to hold the skein holder on a table.

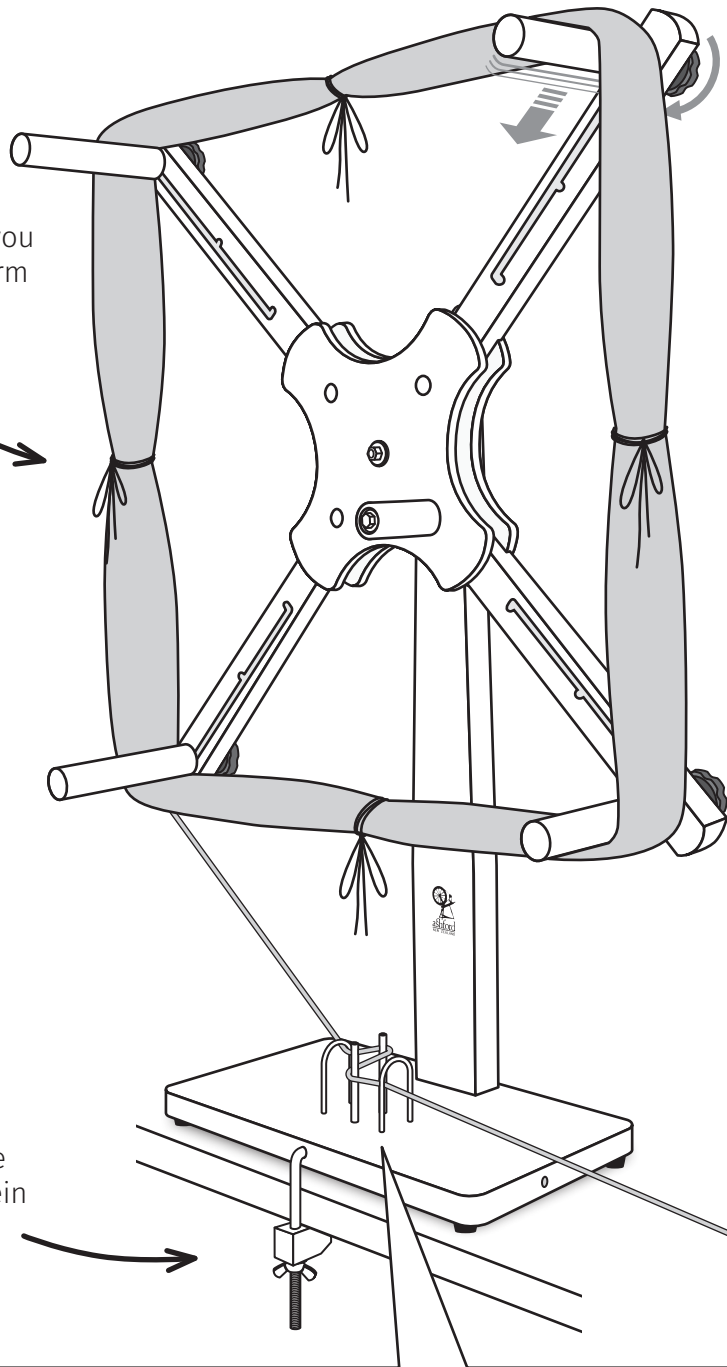
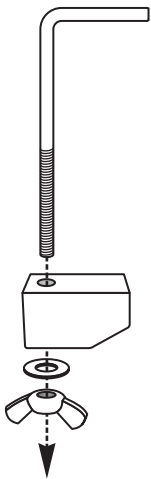

Note

To add tension to your yarn when winding on a skein, thread the yarn through one yarn guide and around one or both tension pins and out through the second yarn guide.

No tension

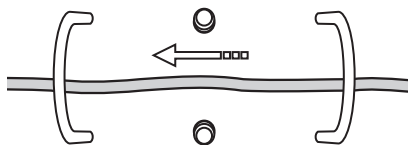

Tension

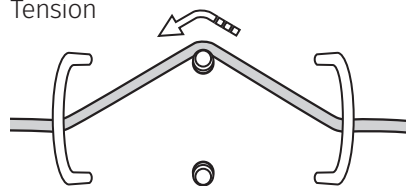

More tension

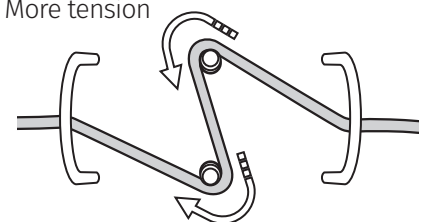

Real Scale Hardware List

