

## KIWI SUPER FLYER

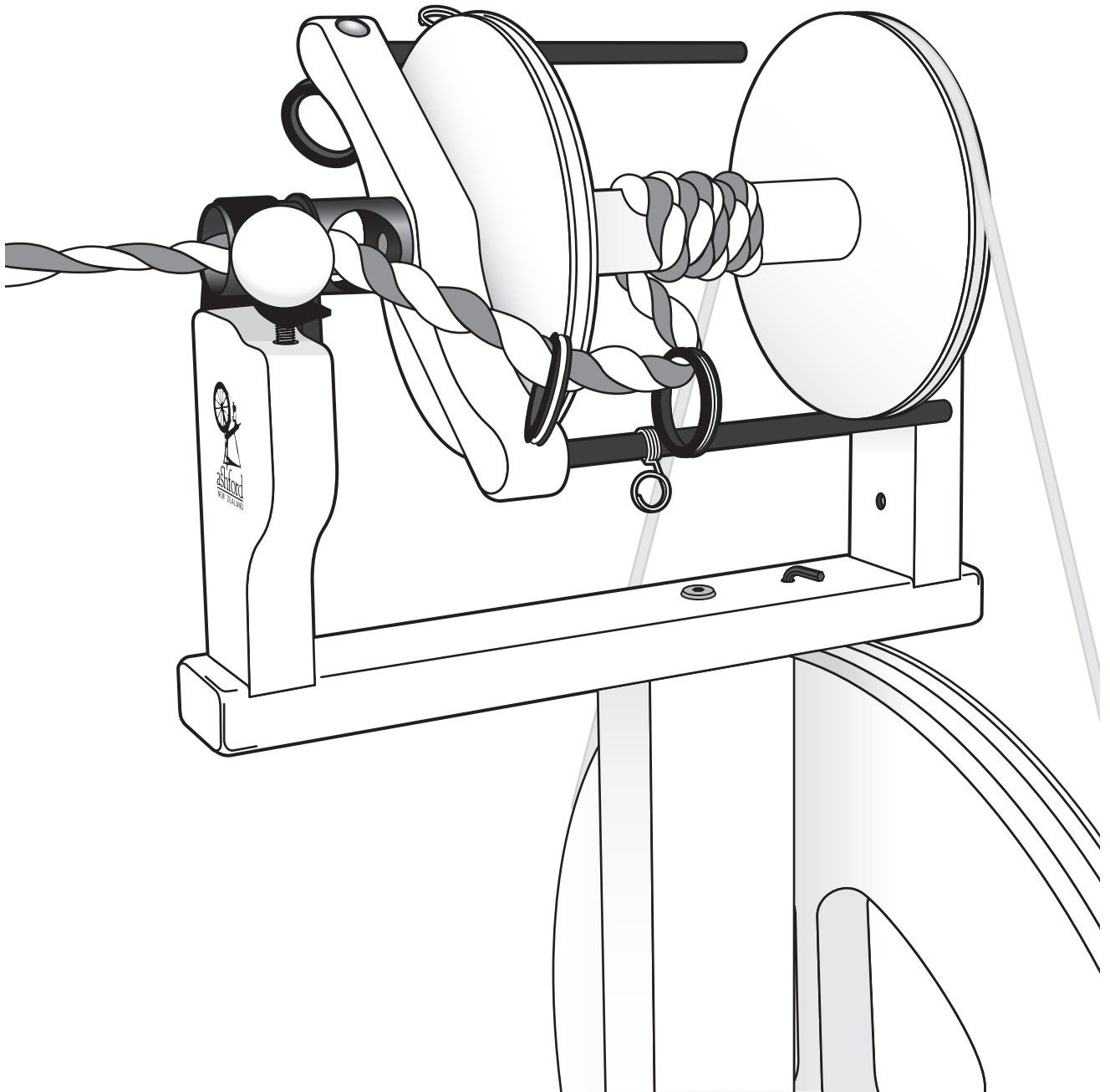

KSF130824

**Ashford Guarantee**

Thank you for purchasing this Ashford product. In the unlikely event of a fault in manufacture, please contact the dealer you purchased it from.

**Ashford Blog**

For inspirational articles, patterns and projects. Subscribe for free [www.ashford.co.nz/blog](http://www.ashford.co.nz/blog)

# THE ASHFORD KIWI SUPER FLYER

This fantastic flyer gives you the freedom to spin your fibre into fabulous, fun and funky art yarns on your Kiwi spinning wheel. With the enormous 27mm (1 1/8ins) orifice and free-flow yarn guides you can spin and ply fibres, feathers, fabric, ribbon, cocoons and more. The free-flow yarn guides ensure your yarn doesn't snap or catch.

## FEATURES

- Enormous 27mm (1 1/8ins) orifice and yarn guides
- Flyer comes with 3 super bobbins plus lazy kate
- Fill your bobbins evenly with the squeeze and slide stainless steel yarn guides
- Fibreglass arms result in a light and strong flyer

## ASSEMBLY INSTRUCTIONS

Before commencing, please read the instructions completely, identify the parts and note the assembly sequence.

### Timber

We recommend that the wood surfaces be waxed or sealed before assembly. This protects the kiln dried wood from climatic changes and prevents it getting

dirty or stained. The Beech timber has a lovely variety of colour and grain. For a silky smooth matt finish, use the Ashford Finishing Wax Polish to enhance the natural colours and character of this timber.

The Kiwi Super Flyer is also available factory finished in clear lacquer.

### Tools Required

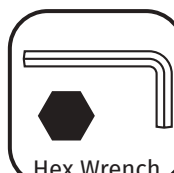

included

### Real Scale Hardware List

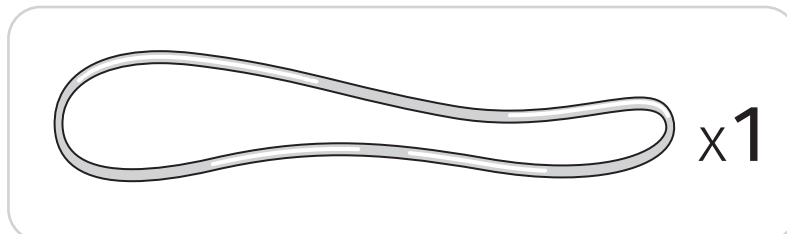
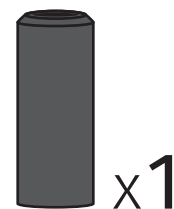
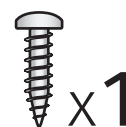
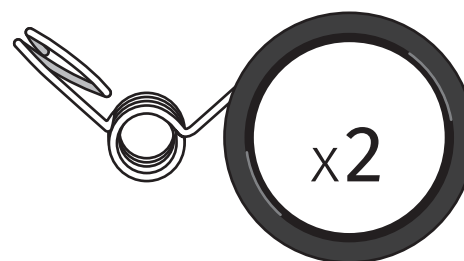
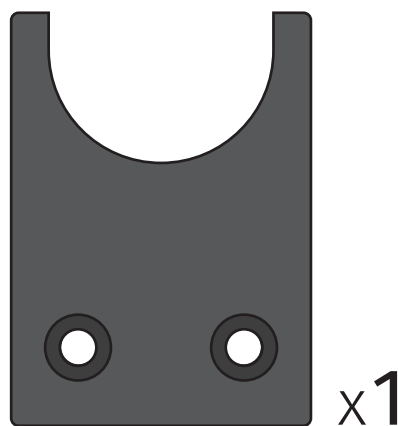
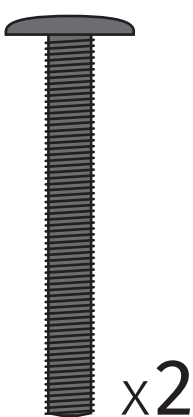

# Hints

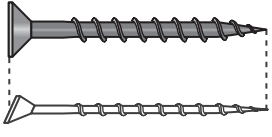

Check hardware against full size illustration.

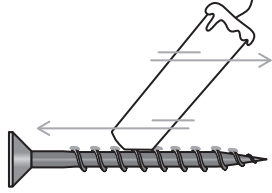

To make assembly easier use candle wax on the screws.

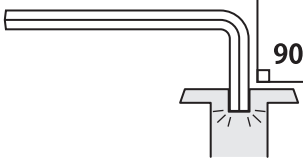

When you use the Hex wrench, make sure it is at 90 degrees and is at the bottom of the hole.



Check the directions carefully.

**1** 

Gently tap the lazy kate pins into the lazy kate base and locate the bobbins on them for storage and plying. Stop tapping when the pins reach the bottom of the holes.

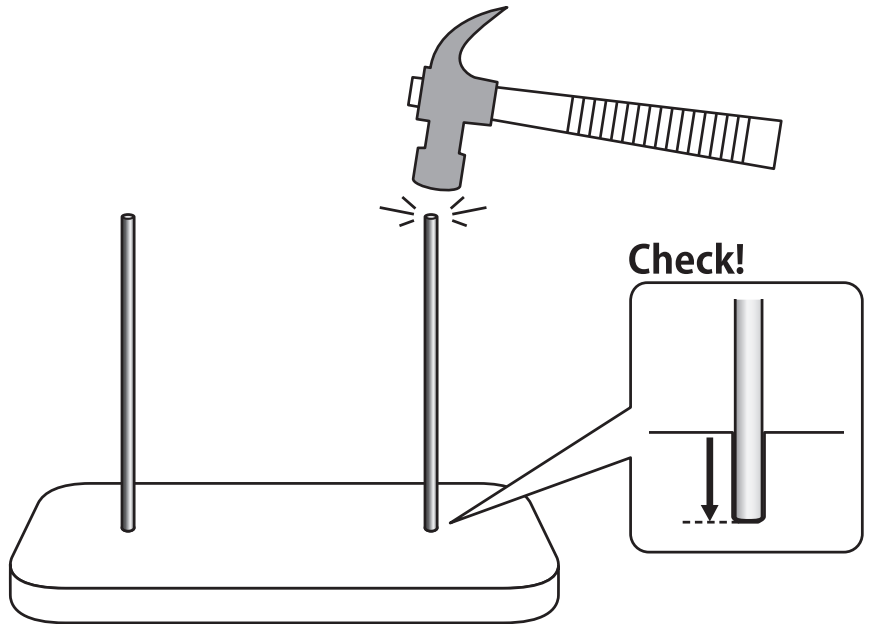
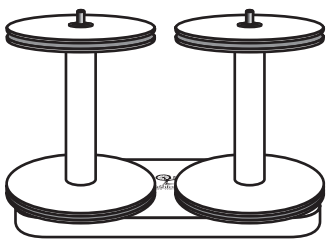

**2** 

Squeeze and slide the yarn guides onto the flyer arms. Apply a drop of oil to the flyer shaft and slide a bobbin into position.

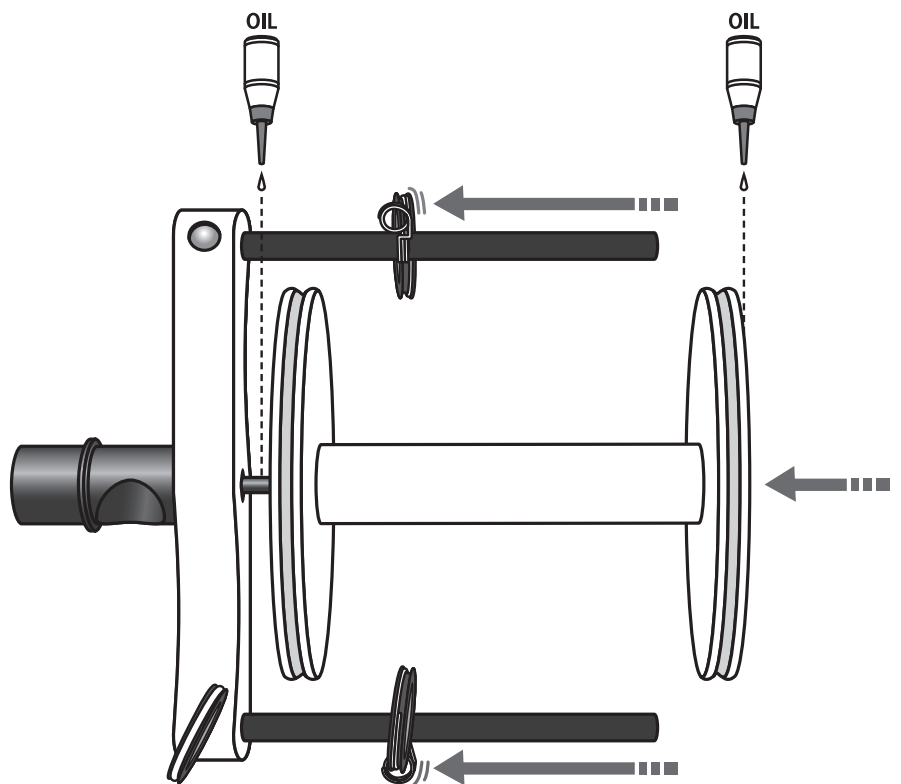
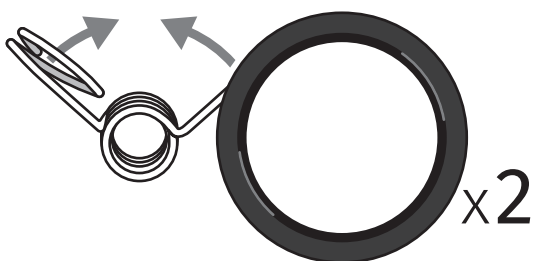



Attach the front flyer bearing with the large slot to the front flyer support with 19mm (3/4") screws.

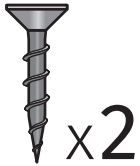
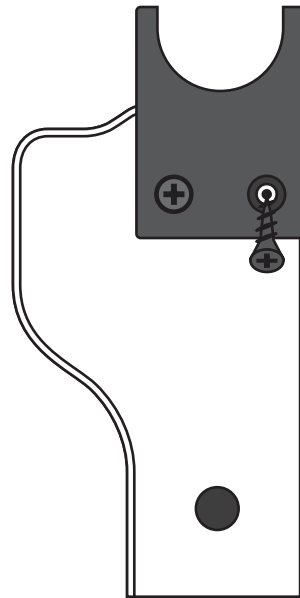
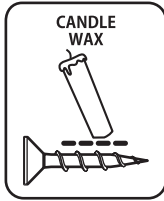

Tap the nylon bearing down to the bottom of the hole in the rear flyer support.

Check!

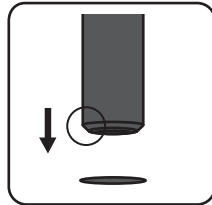

Check!

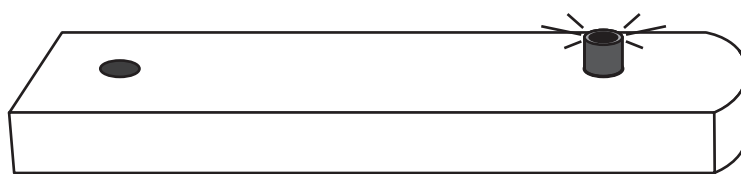
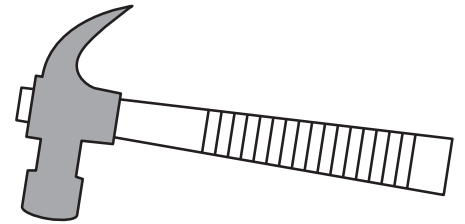
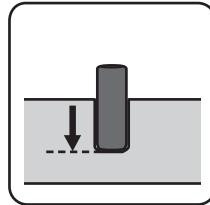

Secure the front and back flyer supports to the maiden bar with 50mm (2") bolts and barrel nuts. Note: the holes in the maiden bar are closest to the rear flyer support.

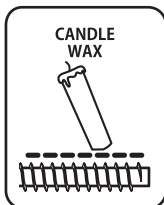

Check!

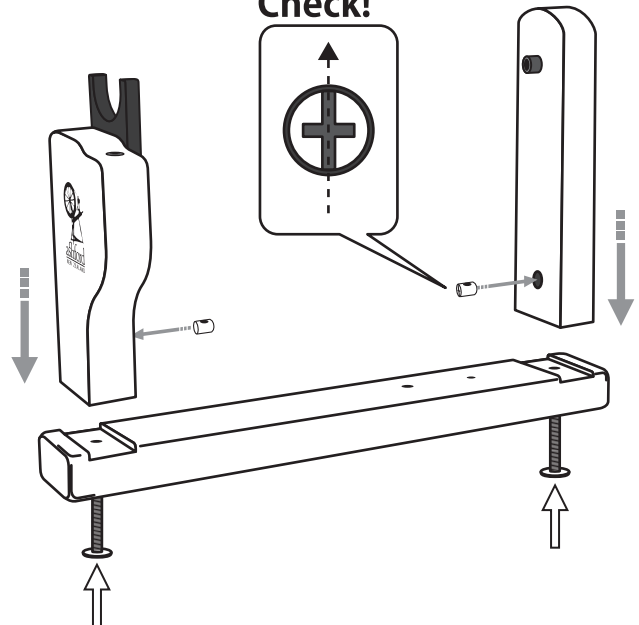

**6** 

Use the Hex wrench to remove the original maiden bar and carefully store with the flyer, bobbins, lazy kate and drive band.

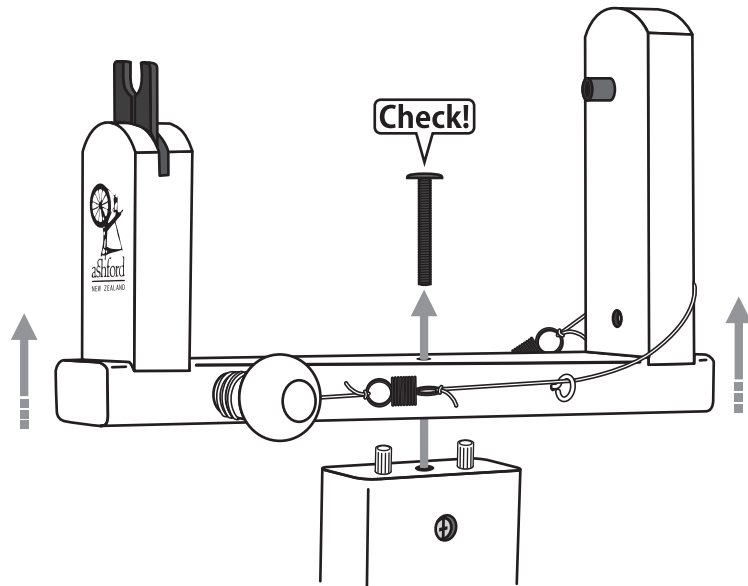

**7** 

Place the new Super Flyer maiden bar onto the dowels in the main upright and secure with the 50mm (2") bolt and barrel nut. If required, tap new wooden dowels into the holes in the top of the main upright.

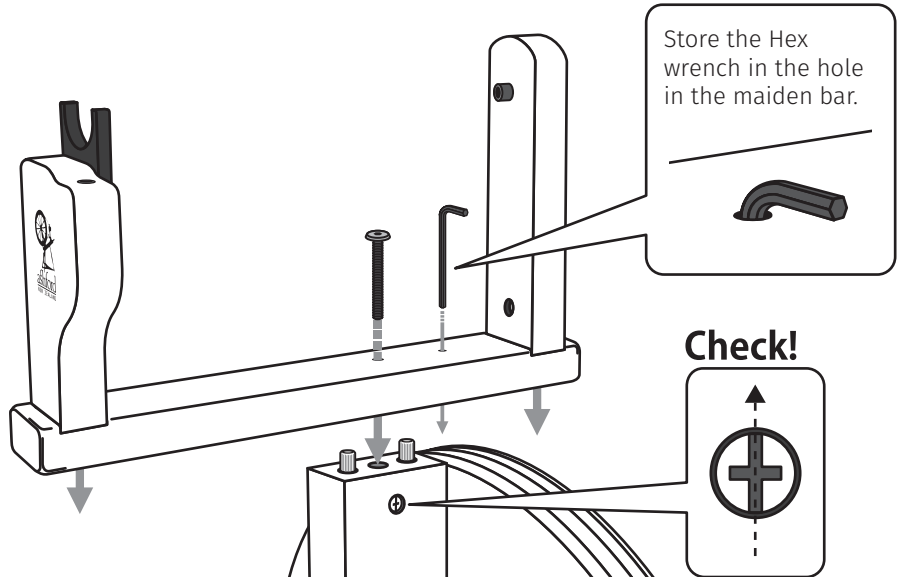

**8**

Insert the end of the flyer shaft into the rear flyer bearing and the flyer orifice onto the front flyer bearing.

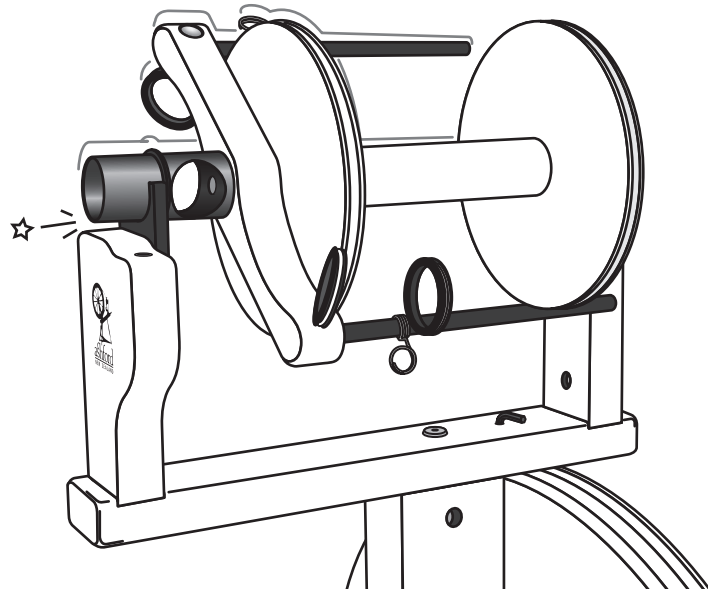



Attach the leather brake to the front flyer support with a 15mm ( $\frac{5}{8}$ " ) round head screw. Apply a drop of oil to the flyer shaft. Thread the tension knob through the leather brake band and into the front flyer support.

**HINT:** The Super Flyer is bobbin lead and will require very little tension on the leather brake band to draw the yarn onto the bobbin. Only apply a minimum tension.

**Check!**

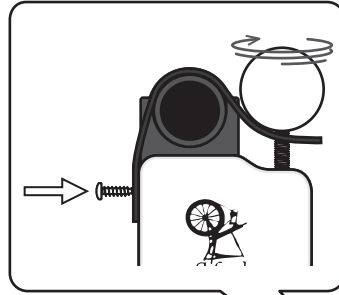

**Check!**

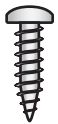
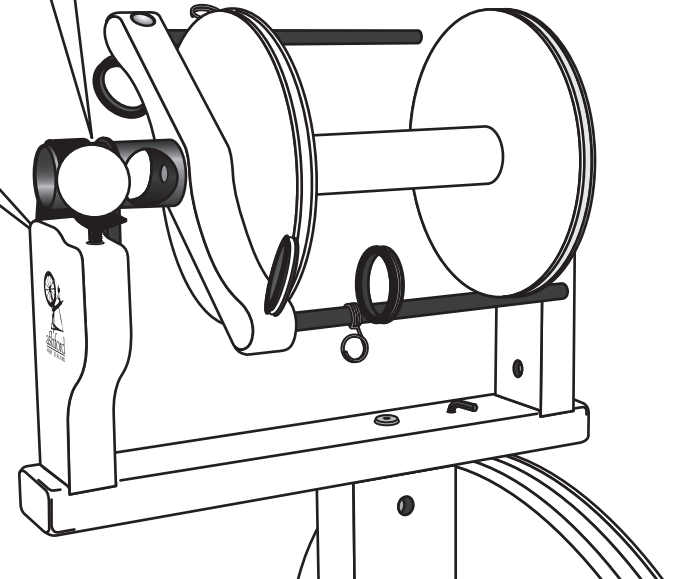
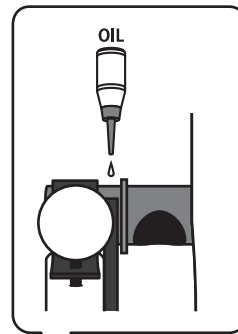

**10**

Locate the new drive band around the bobbin whorl and small groove in the wheel. This gives a flyer to wheel ratio of 3.0:1. For a slightly higher flyer speed, locate the drive band on the large groove in the wheel. This gives a flyer to wheel ratio of 3.2:1.

**NOTE.** When not using your Kiwi Spinning Wheel, please loosen the drive belt to avoid it stretching.

**Check!**

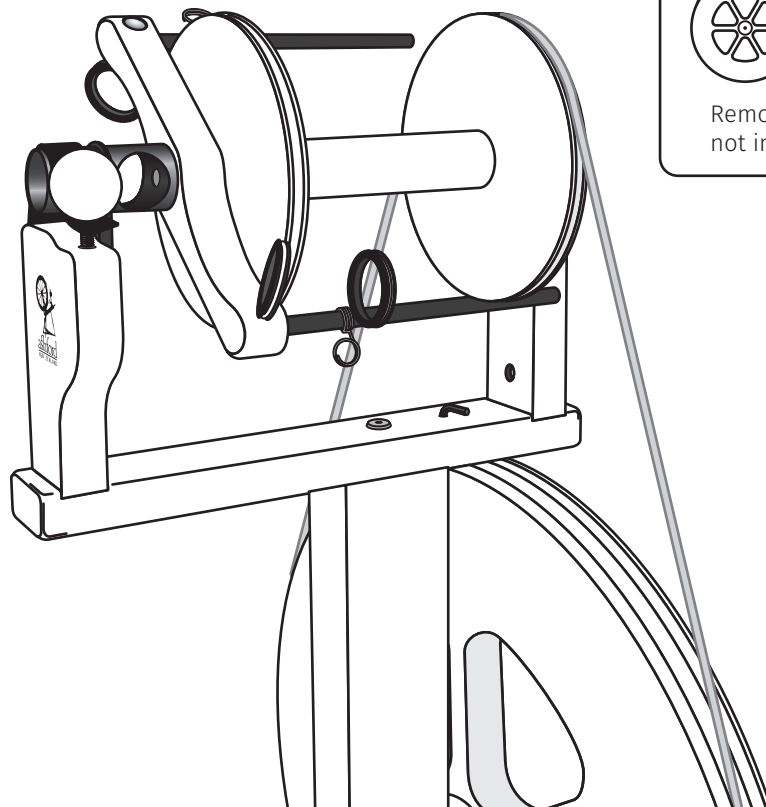
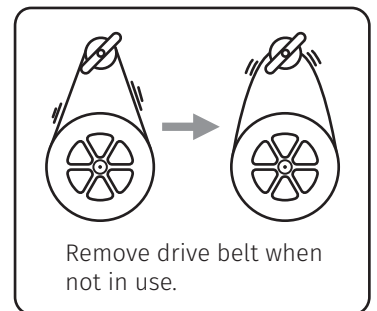

11



To make spinning easier apply a drop of Ashford Spinning Wheel Oil to the flyer, bobbin and conrod bearings.

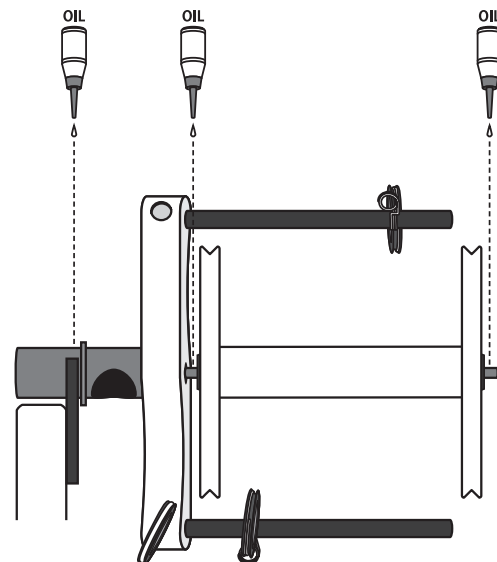
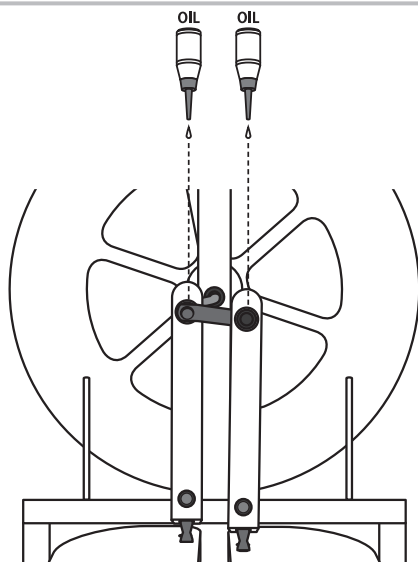

## Spinning on the Kiwi Super flyer

Because the Kiwi Super Flyer is bobbin lead, your yarn needs to be strong enough to turn the flyer.

- Place the drive belt in the inside wheel groove. This gives a 3.0:1 ratio.
- Loosen the leather brake so there is no tension on the flyer shaft.
- Tie a 1.5m (5') leader to the bobbin. Thread it through the flyer yarn guides with the black inserts on the **right-hand side of the flyer** and out through the orifice.

- Start treadling slowly clockwise (60 RPM is ideal).
- Allow your prepared fibre to join onto the leader, then feed the spun yarn onto the bobbin.
- If your yarn kinks, is over twisted or won't feed on, treadle slower, draft a thinner yarn and increase the brake tension.
- If your yarn breaks, treadle faster, move the drive belt to the outside wheel groove, draft a thicker yarn, reduce the brake tension, oil the bearings and apply a drop of oil between the leather brake band and flyer shaft.

\*To change back to the original flyer simply remove the bolt securing the maiden bar to the main upright, swap the flyer units over, retighten and fit the original drive belt.

Refer to The Ashford Book of Hand Spinning for more spinning hints.

*Happy spinning.*

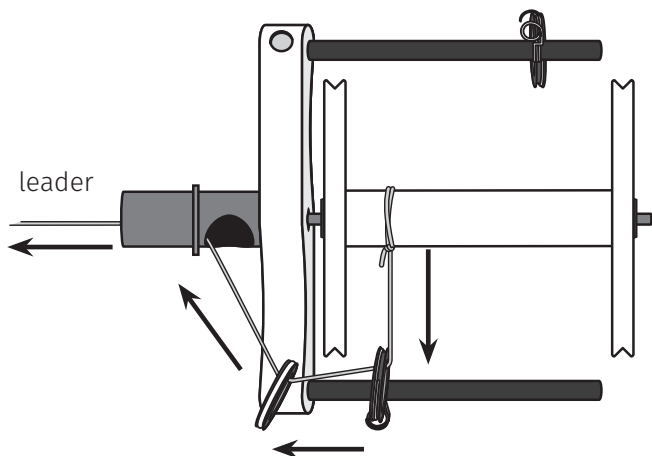

## More Information



### How-to videos on You Tube

Watch our how-to videos on You Tube.  
@AshfordNZ



### Blog

For inspirational articles, patterns and projects. Subscribe for free to the Ashford Blog  
[www.ashford.co.nz/blog](http://www.ashford.co.nz/blog)



### Facebook

Join us on facebook [ashford.wheels.ooms](https://www.facebook.com/ashford.wheels.ooms)

**ashford**  
WHEELS & LOOMS

Ashford Handicrafts Limited  
415 West Street, Ashburton 7700, New Zealand  
Telephone 64 3 308 9087  
[sales@ashford.co.nz](mailto:sales@ashford.co.nz) [www.ashford.co.nz](http://www.ashford.co.nz)