

Jack Loom
8 Shaft - 97cm (38ins)



JL90ES090724

ASSEMBLY INSTRUCTIONS FOR THE ASHFORD JACK LOOM

Before Assembly

- Please read these instructions from beginning to end, identify all parts and hardware and understand the assembly sequence.
- **BOLTS.** Check and sort the sizes and quantities against the full-size drawing on page 4.
- Rub candlewax on the threads of the wood screws to make assembly easier.

Finishing the wood

The Beech timber has a lovely variety of colour and grain.
This Jack Loom has been finished with a water based lacquer to protect the kiln dried timber from climatic changes and enhance its natural character. To repair and restore the finish use Ashford Finishing Wax Polish to enhance the natural beauty of the wood.

Tools Required

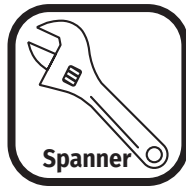

Screwdriver, hammer, candlewax, wood glue, light lubrication oil, adjustable spanner and a ruler.

Hints

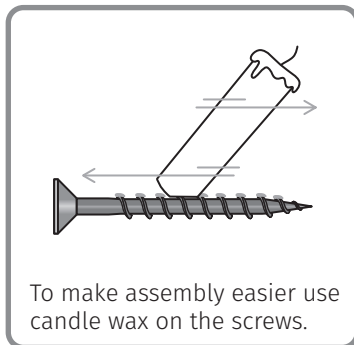
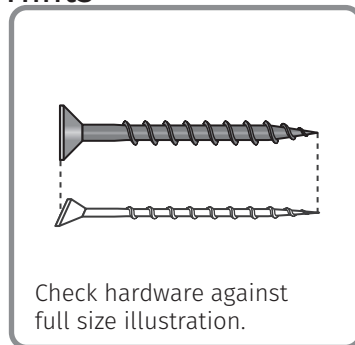

More Information



How-to videos on You Tube

Watch our how-to videos on You Tube.
@AshfordNZ



Blog

For inspirational articles, patterns and projects. Subscribe for free to the Ashford Blog www.ashford.co.nz/blog



Facebook

Join us on facebook [ashford.wheels.ooms](https://www.facebook.com/ashford.wheels.ooms)

OVERVIEW

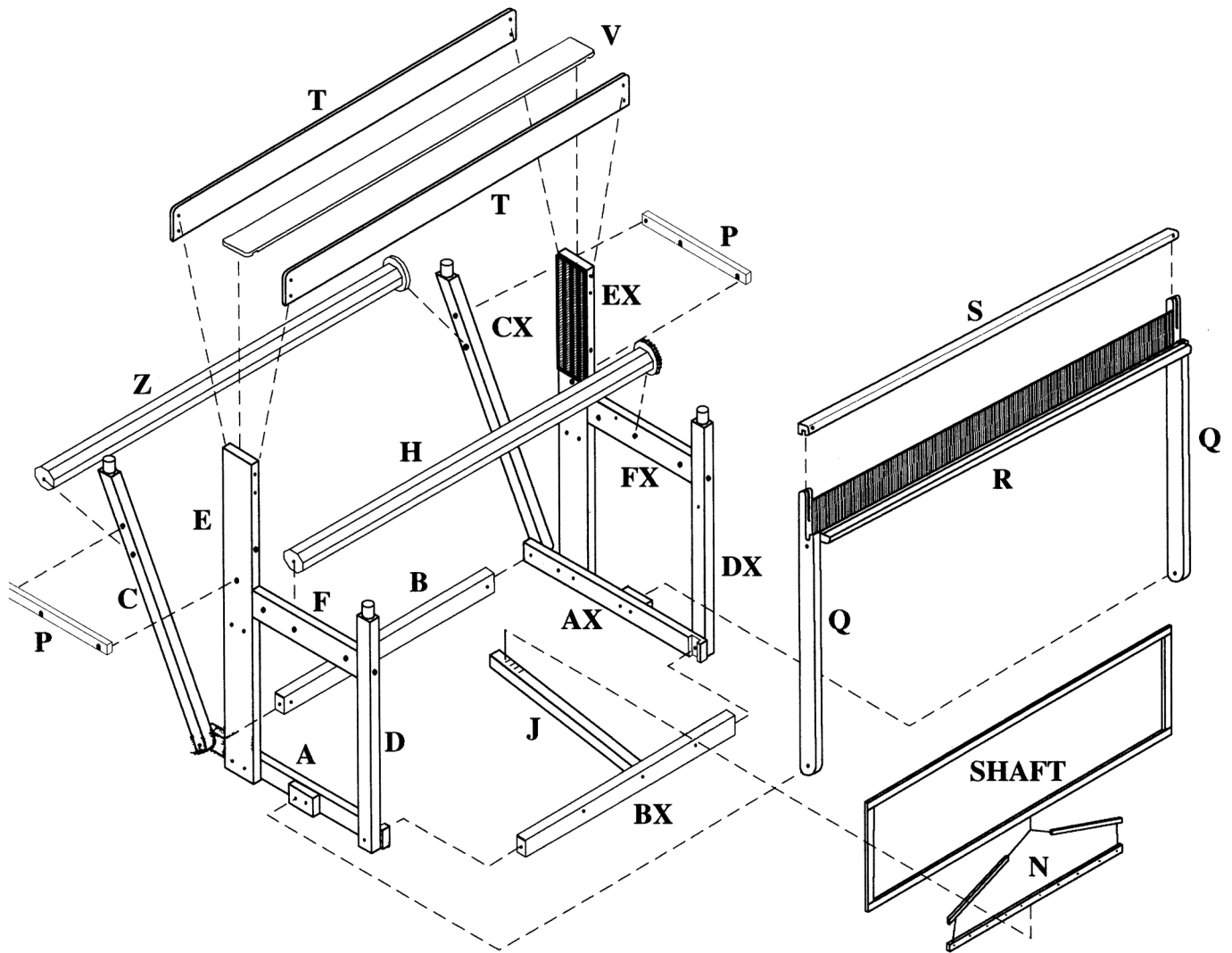

HARDWARE CHECKLIST

- | | | |
|----------------------------|--------------------------------|---|
| 1 – M8 x 50 Hex Head Bolt | 2 – 38mm Clip Rings | 2 – M10 Spanner |
| 6 – M6 x 80 Hex Head Bolt | 8 – 8 x 1 ½ Screw | 1 – M13 Spanner |
| 2 – M6 x 100 Hex Head Bolt | 1 – 12 x 1 Pan Head Screw | 6 – M6 Nylon Knob |
| 2 – M6 x 65 Hex Head Bolt | 2 – 6 x ½ Pan Head Screw | 101 – Texsol Straight Peg |
| 1 – M8 x 100 Cup Head Bolt | 1 – M11 x 4 Brass Spacer | 16 – Harness Hook |
| 4 – M6 x 50 Cup Head Bolt | 1 – 6.3 x 40 Cotter Pin | 1 – Heddle Hook - Double ended |
| 1 – M6 x 40 Cup Head Bolt | 3 – 50mm Screw Hook | 1 – Heddle Hook - Metal |
| 9 – M6 x 65 Cup Head Bolt | 1 – M8 Hex Nut | 80 – Texsol Treadle Cord 30cm |
| 2 – M6 x 75 Cup Head Bolt | 1 – M10 Hex Nut | 14 – Texsol Warping Cord 80cm |
| 3 – M6 x 70 Cup Head Bolt | 1 – M8 Nylock Nut | 8 – Texsol Heddles 268, bundles of 100 |
| 28 – M6 X 16 Washer | 15 – M6 Nylock Nut | 6 – M8 x 172 Steel Rods - Lever Assembly |
| 6 – M6 x 22 Washer | 16 – M11 Rubber Buffer | 2 – 5/8 x 75 Steel Shaft - Cloth beam and Warp Roller |
| 1 – M8 x 19 Washer | 2 – M16 Rubber Buffer | 2 – M6 x 180 Threaded Rod with Dome Nut |
| 48 – M8 x 25 Washer | 20 – 3/32 Dome Caps (4 spares) | |
| 8 – 8 x 2 Screw | 10 – M6 Barrel Nut | |

REAL SCALE HARDWARE

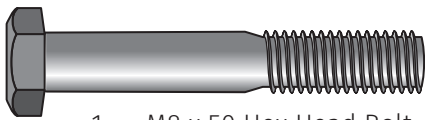

1 - M8 x 50 Hex Head Bolt



1 - M10 Hex Nut



1 - M8 Hex Nut



2 - M6 x 100 Hex Head Bolt

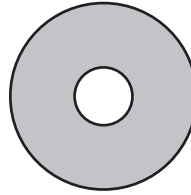

48 - M8 x 25 Washer

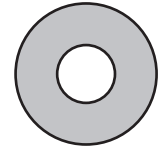

1 - M8 x 19 Washer



6 - M6 x 80 Hex Head Bolt

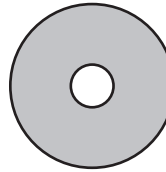

6 - M6 x 22 Washer

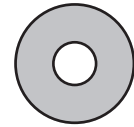

28 - M6 X 16 Washer



2 - M6 x 65 Hex Head Bolt

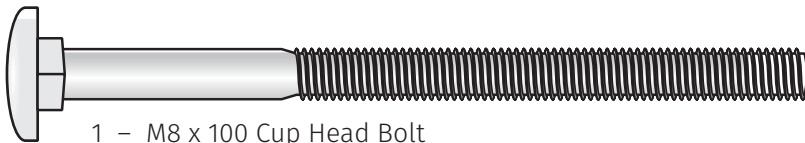

1 - M8 x 100 Cup Head Bolt



1 - M8 Nylock Nut



15 - M6 Nylock Nut

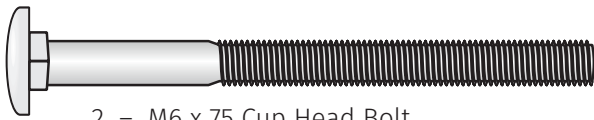

2 - M6 x 75 Cup Head Bolt



10 - M6 Barrel Nut



2 - M16 Rubber Buffer



3 - M6 x 70 Cup Head Bolt



20 - 3/32 Dome Cap



16 - M11 Rubber Buffer



9 - M6 x 65 Cup Head Bolt



8 - 8 x 1 1/2 Screw



1 - M11 x 4 Brass Spacer



4 - M6 x 50 Cup Head Bolt



8 - 8 x 2 Screw

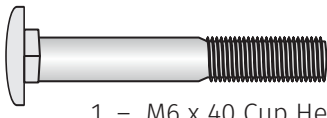

1 - M6 x 40 Cup Head Bolt

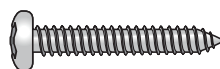

1 - 12 x 1 Pan Head Screw



2 - 6 x 1/2 Pan Head Screw

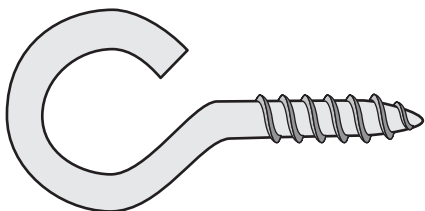

3 - 50mm Screw Hook



1 - 6.3 x 40 Cotter Pin

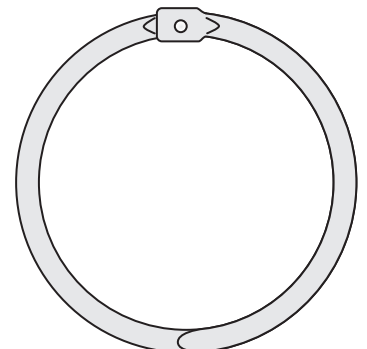

2 - 38mm Clip Ring



2 - 5/8 x 75 Steel Rod



101 - Texsol Straight Peg



16 - Harness Hook



6 - M8 x 172 Steel Rod

PARTS

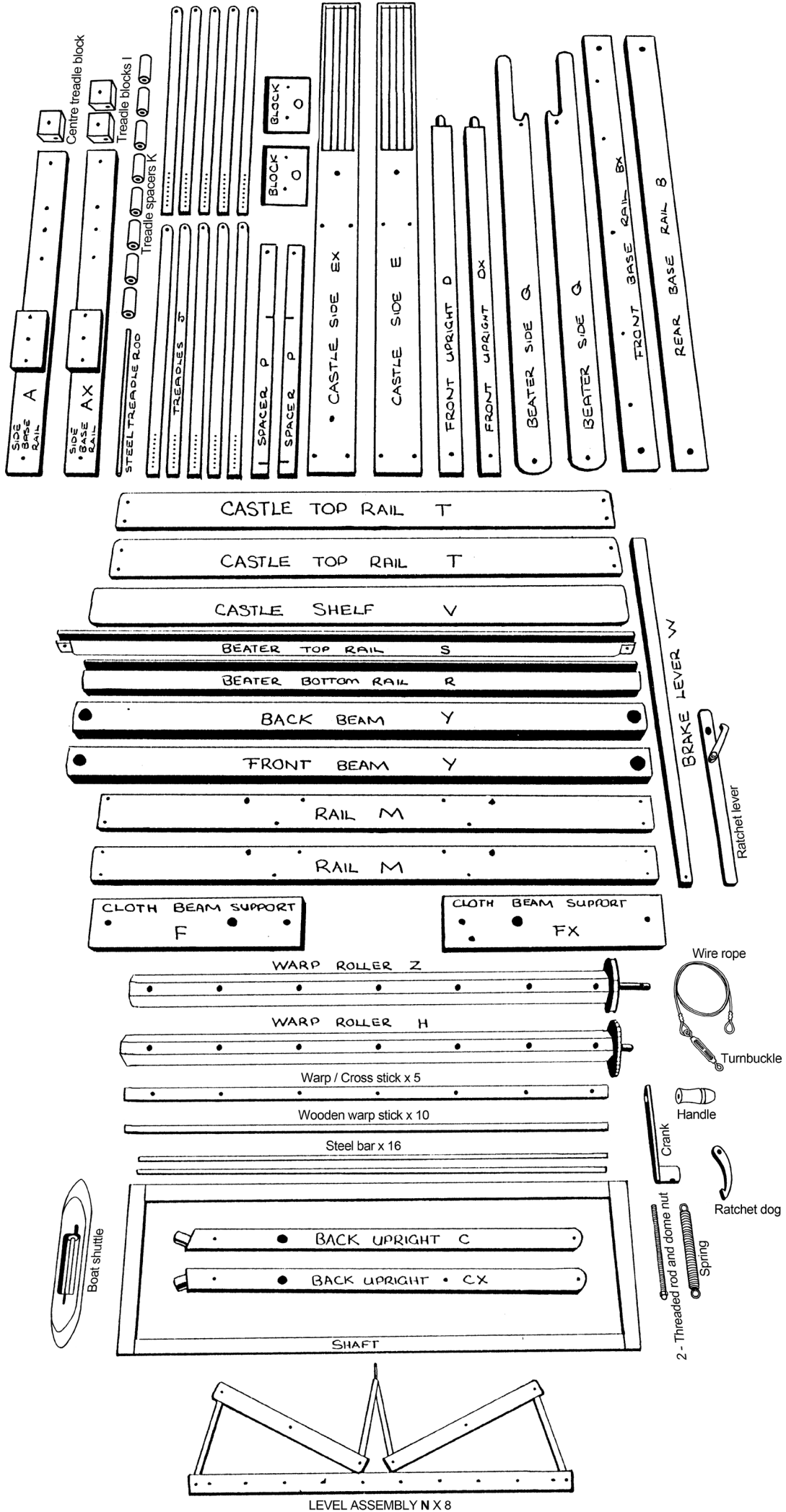

ASSEMBLY OF THE LOOM

1. Assemble the base using M6 x 80 Hex Head Bolt, M6 X 16 Washer and M6 Barrel Nut. **Note:** The holes in rail BX are to the top. Nylon bushes in parts C and CX are on the inside.

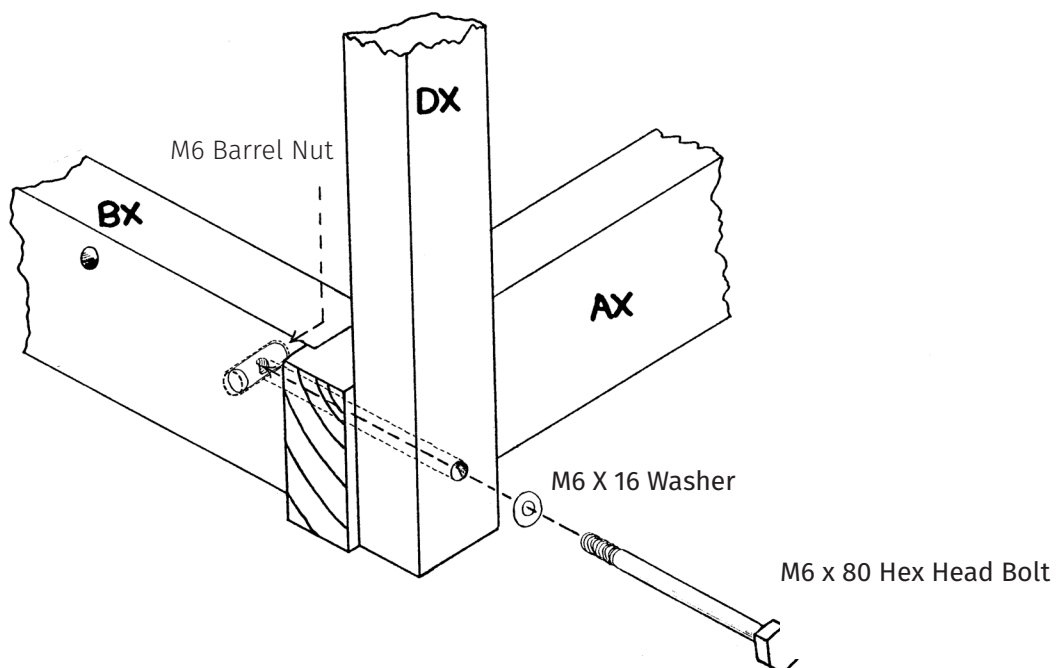
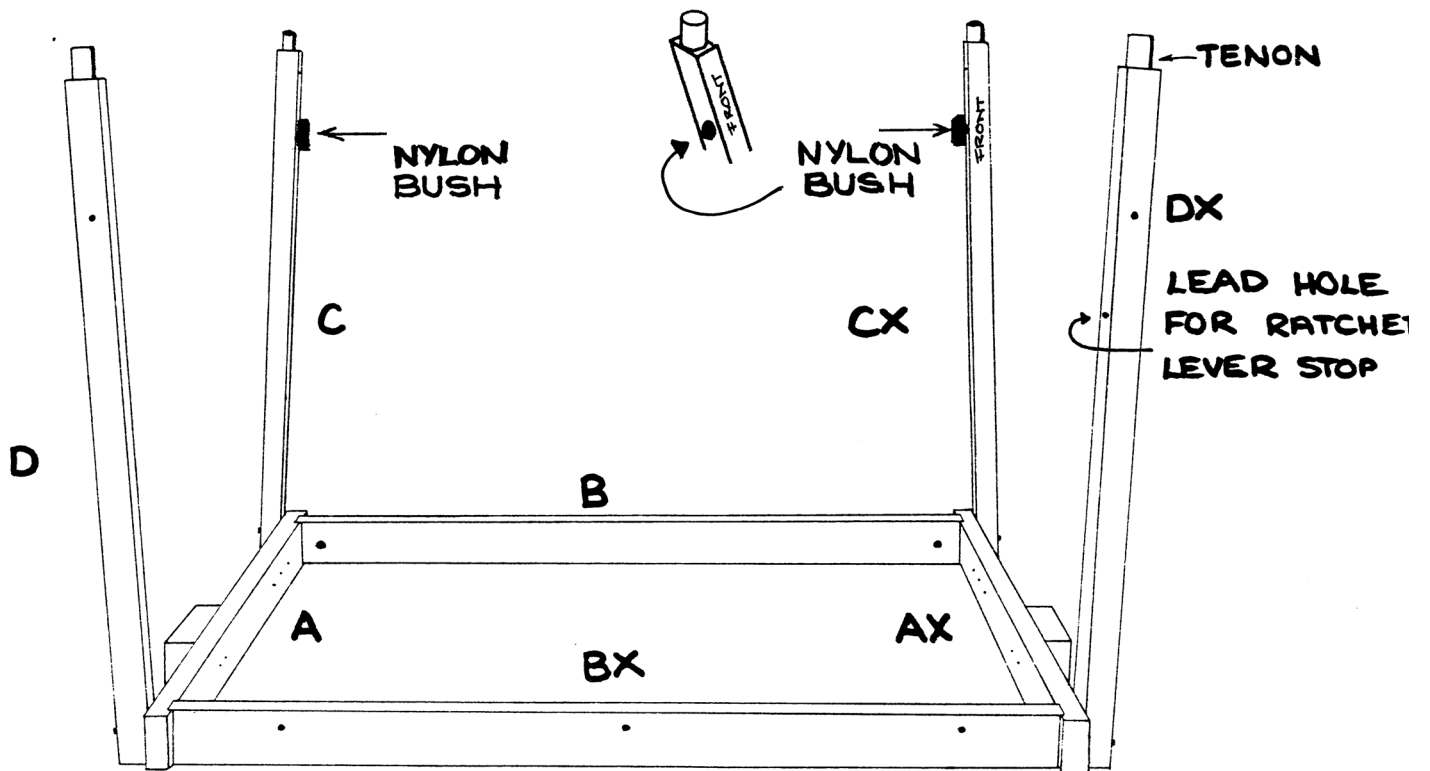

2. Bolt castle side **E** to the outside of base rail **A**, and the castle side **EX** to the base rail **AX** using M6 x 65 Cup Head Bolts, M6 X 16 Washer and M6 Nylock Nut. Tap the head into the wood with a hammer.

Note: The nylon shaft guides are to the inside of the frame and holes for the beater stops face forward.

3. Secure the blocks **O** to the inside of the castle sides **E** and **EX** with M6 x 65 Cup Head Bolts, M6 X 16 Washer and M6 Nylock Nuts. Tap the head into the wood with a hammer. **Note:** The rubber buffer is to the top.

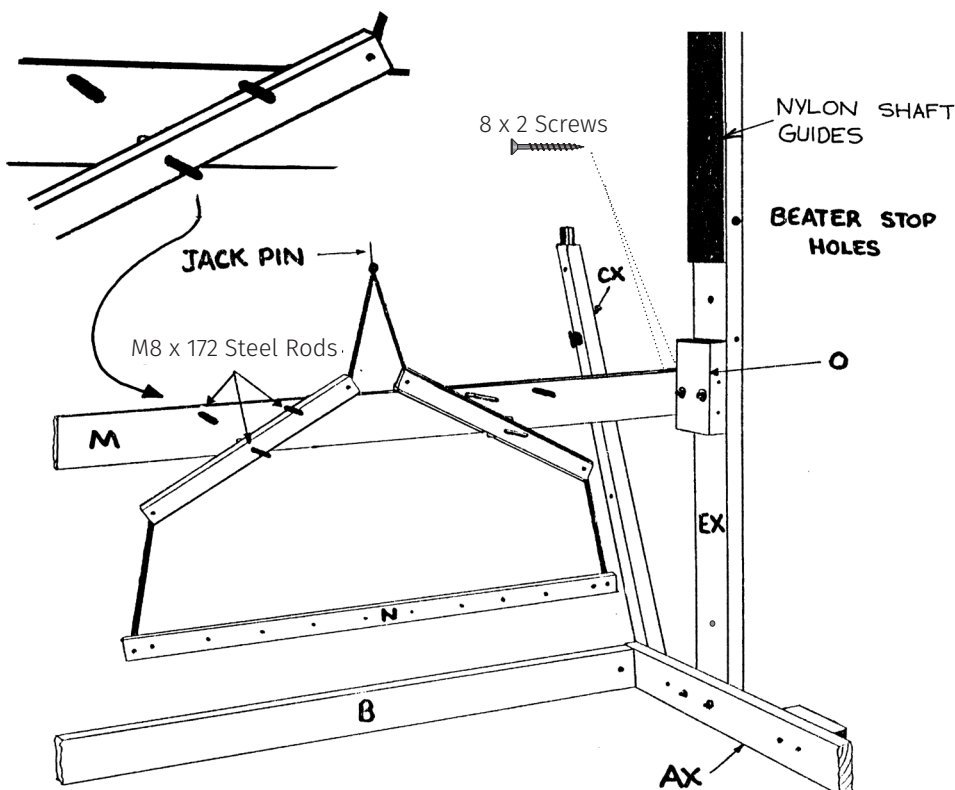
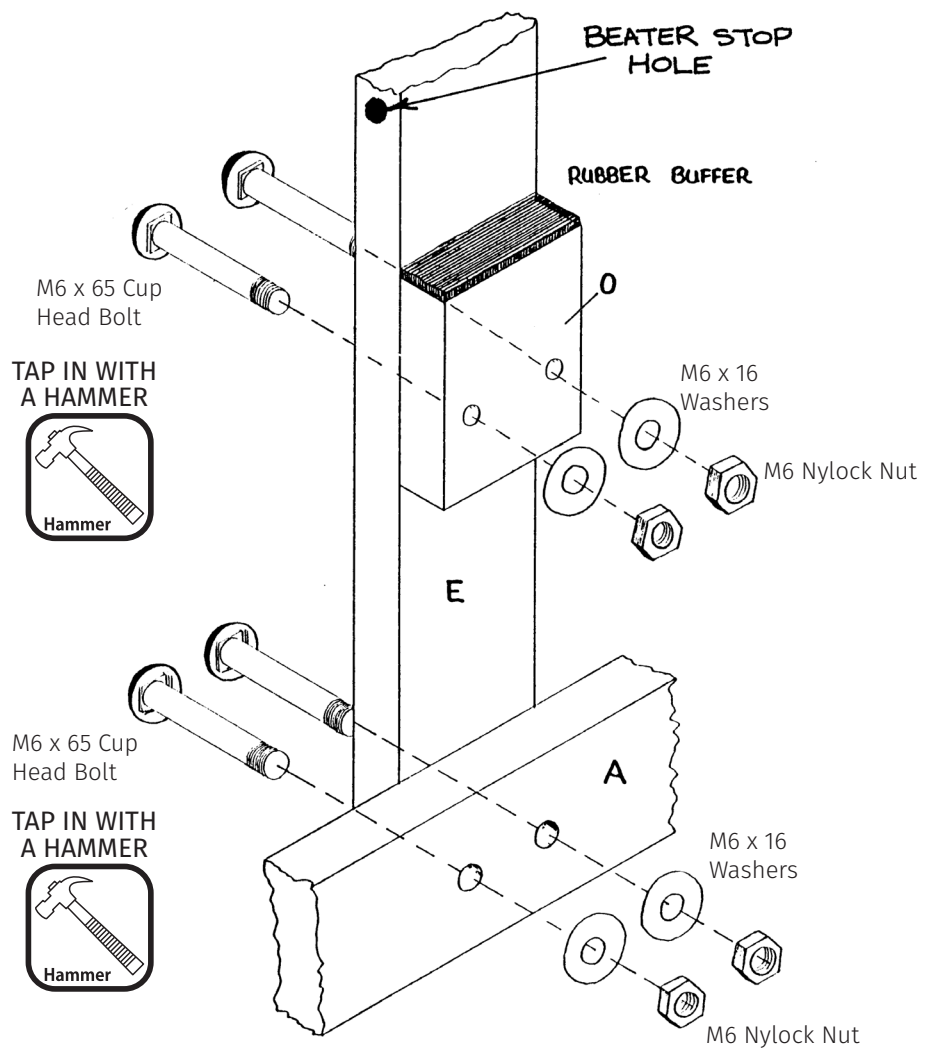

4. Secure one rail **M** to blocks **O** using two 8 x 2 Screws at each end. Note the position of the holes for the steel rods **x**.

5. Place the six M8 x 172 Steel Rods into the rail **M**.

6. Apply a drop of oil onto the two lower steel rods. Then slide 5 x M8 x 25 washers onto the two lower steel rods followed by a lever assembly **N**. Place two washers onto each lower steel rod followed by another lever assembly **N**. Repeat this procedure until all the lever assemblies are in position, finishing with 5 washers.

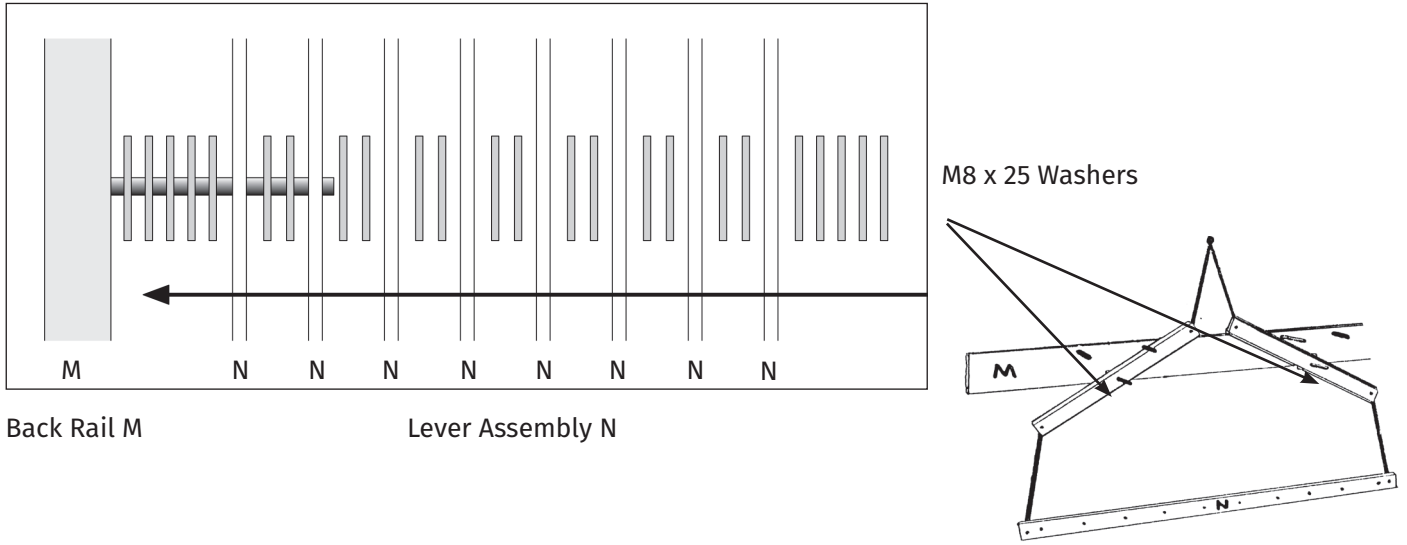

Back Rail M

Lever Assembly N

7. Locate the second rail **M** onto the steel rods and secure to blocks **O** using two 8 x 2 Screws at each end.
8. Identify the cloth beam supports **F** (left) and **FX** (right). **FX** has a counter-bored hole on the outside.
9. Attach **but do not** tighten **FX** to **DX** with a M6 x 80 Hex Head Bolt, M6 X 16 Washer and M6 Barrel Nut and attach to **EX** with the M6 x 180 Threaded Rod with Dome Nut and M6 X 16 Washer. Repeat for the opposite side with **F**, **D** and **E**. Keeping the nylon bushes to the inside. **Note:** The nylon bushes are towards the rear.
10. Slide the ratchet lever **G** onto the steel shaft on the cloth beam **H** and ensure the pawl engages the ratchet teeth.
11. Twist the cloth beam support **FX** up slightly and locate the cloth beam **H** into the nylon bush. Lower **H** so the holes in **H** and **F** line up and then carefully tap a 5/8 x 75 Steel Shaft through the nylon bush and into **H**. Then tighten the bolts securing **F** and **FX**.

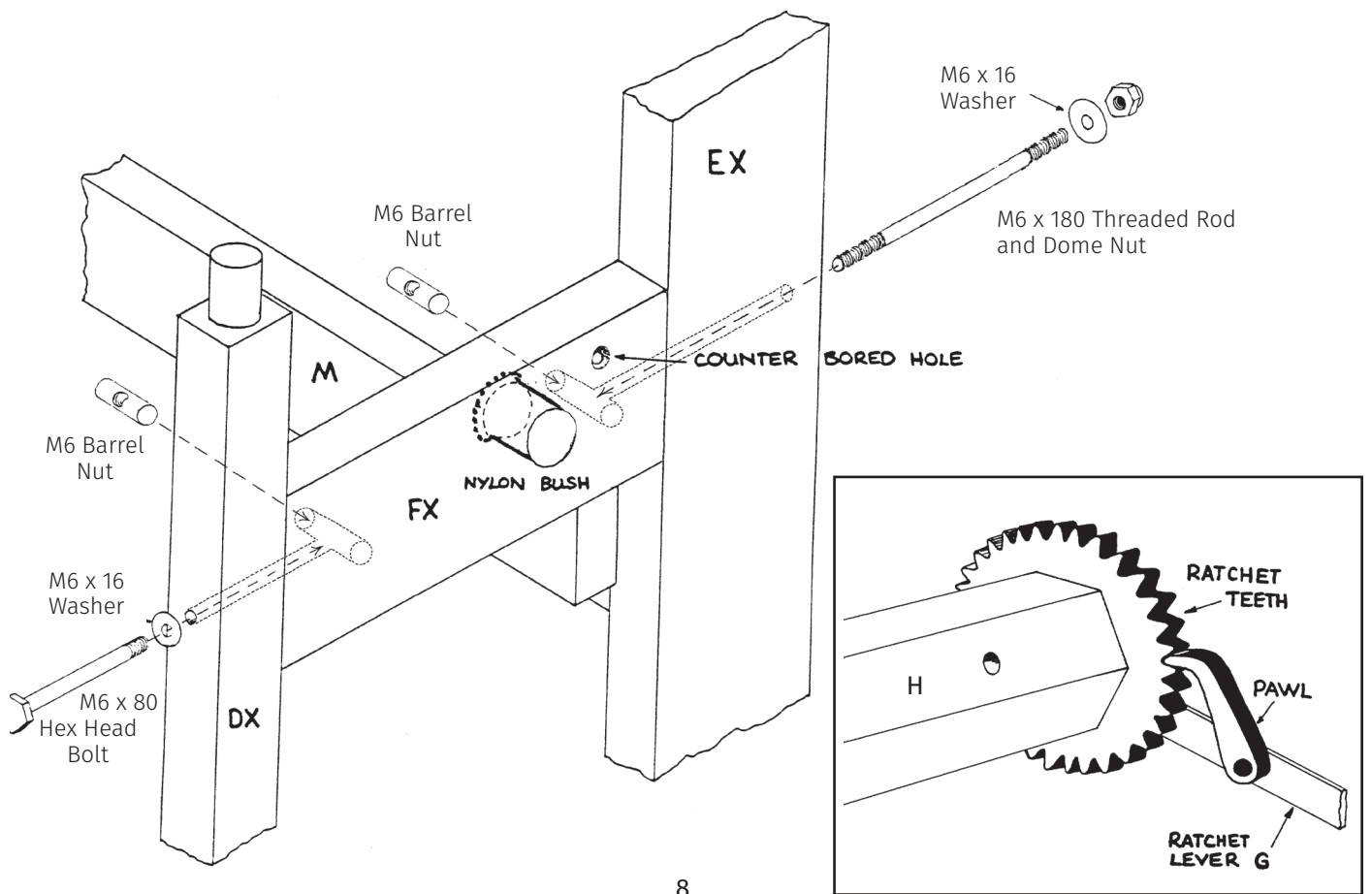

12. Insert the 12 x 1 Pan Head Screw into the inside of the front upright DX for a ratchet lever stop. When transporting the loom lift and pull the lever sideways, then let it hang down.

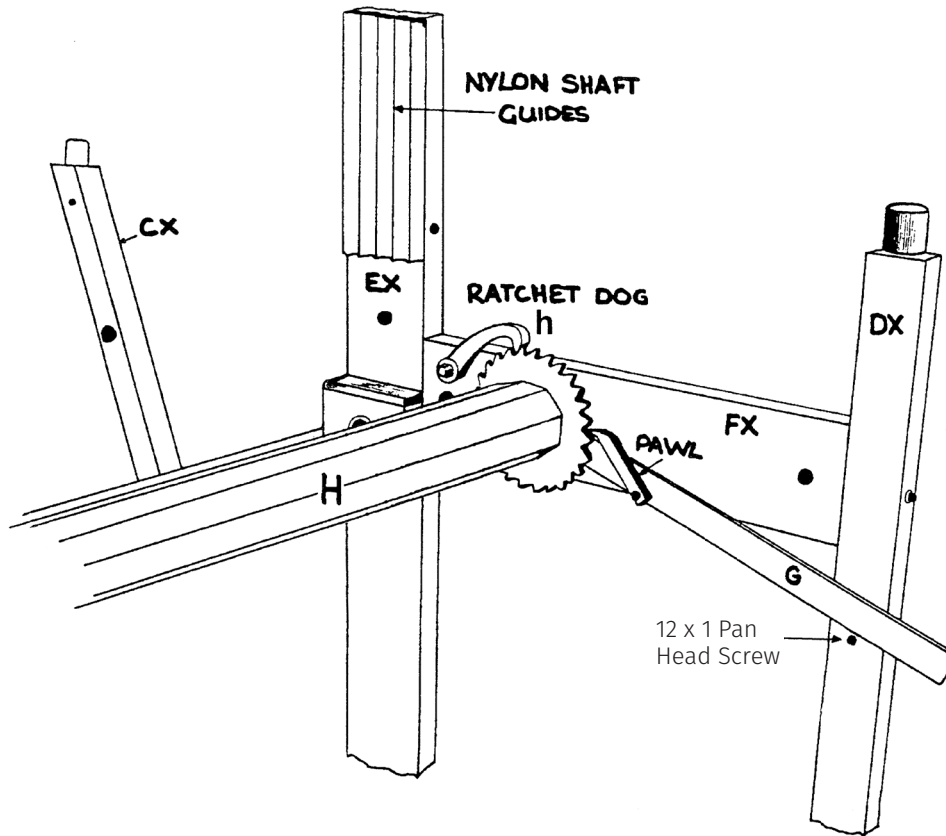

13. Attach the ratchet dog to the right cloth beam support FX using a M8 x 50 Hex Head Bolt, M10 Hex Nut, M8 x 19 Washer and M8 Nylock Nut. Tap the head of the bolt to the bottom of the counter-bored hole. So the head of the nut is flush with the surface of side FX. Do not overtighten the M8 Nylock Nut, as the ratchet dog should move freely after tightening the nut. Note: The M10 Hex Nut is used as a spacer only.

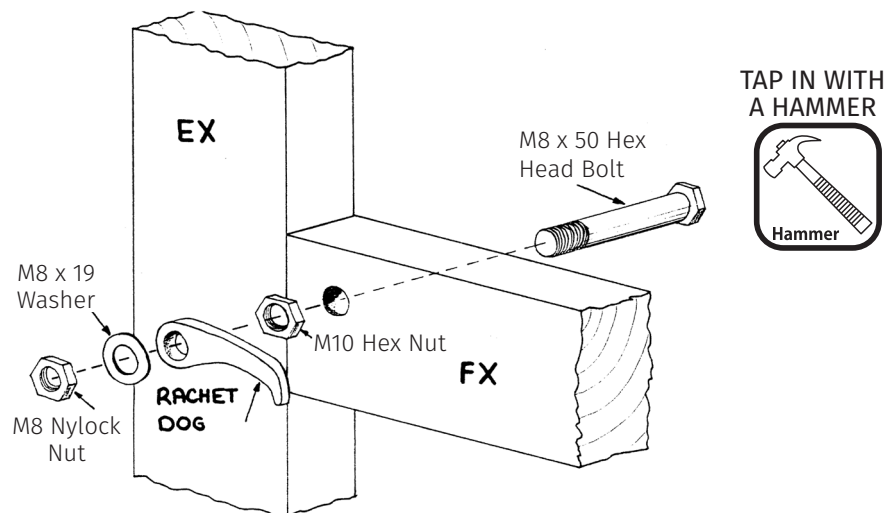

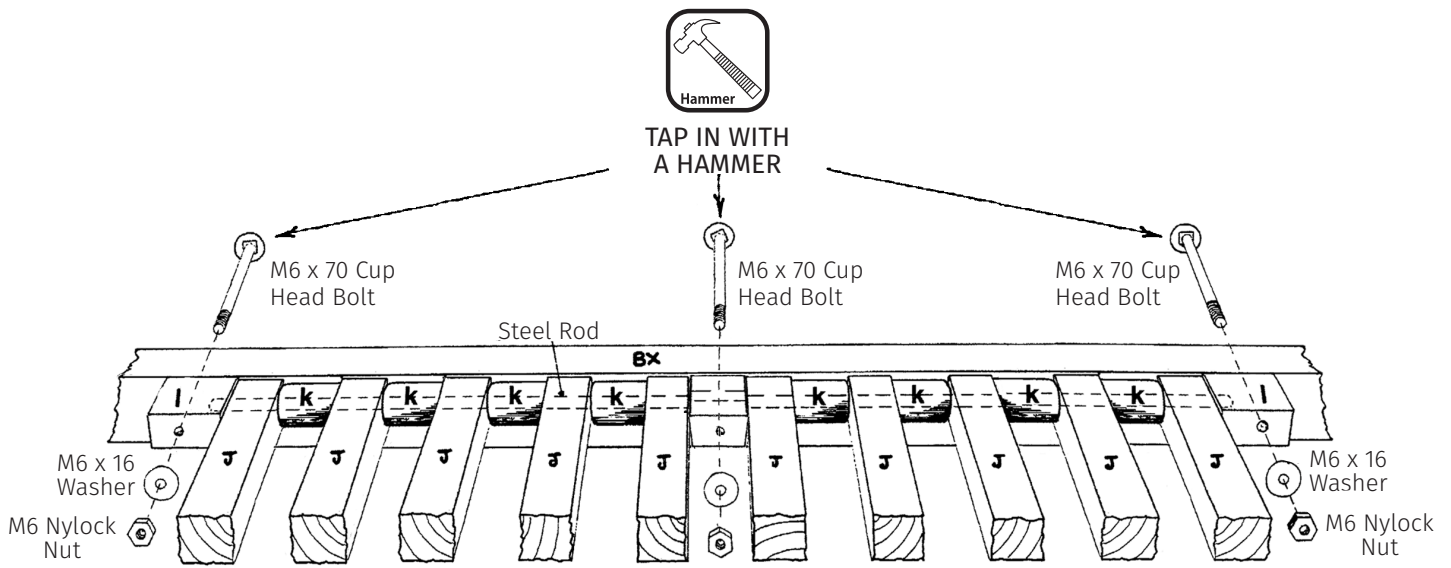

14. Slide 5 treadles J onto the steel treadle rod with a round wooden spacers k between. Add the centre block. Then add the next 5 treadles and round wooden spacers followed by the treadle blocks l at either end. Note that the rod holes in the treadle blocks must be towards the top. Then bolt all 3 blocks to BX with M6 x 70 Cup Head Bolt, M6 X 16 Washer, and M6 Nylock Nut. Tap the head into the wood with a hammer.

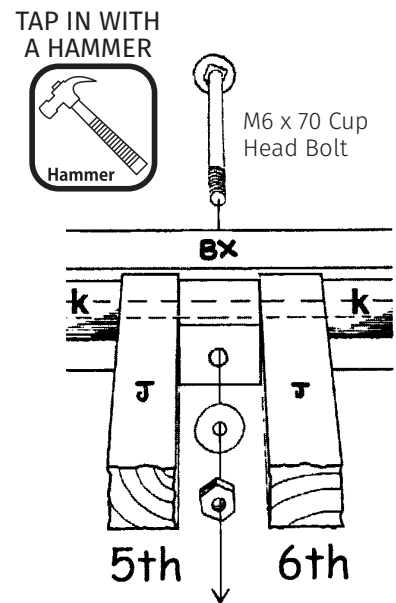

15. Push a M6 x 50 Cup Head Bolt through the inside of back upright CX and tap the head of the bolt into the wood with a hammer. Then attach spacer P through the hole with a M6 x 22 Washer and nylon knob.
16. Push a M6 x 50 Cup Head Bolt through the inside of castle side EX and tap the head of the bolt into the wood with a hammer. **Locate the slot in spacer P** onto the bolt and secure with a M6 x 22 Washer and nylon knob. Repeat for the other side.

Note: The middle slot is used to hold the back beam in the closed position.

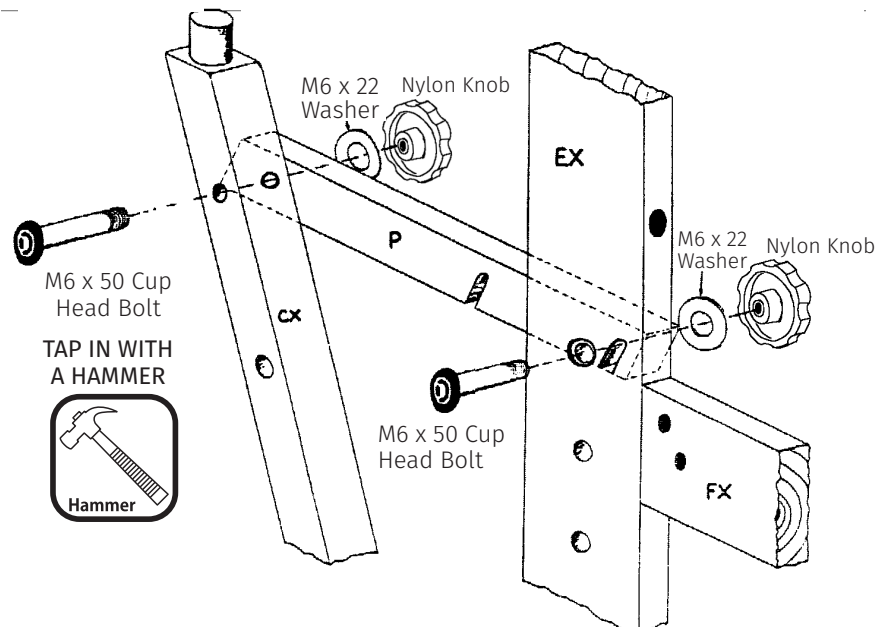

17. Lift the wooden spacer P from the castle E to allow the warp roller Z to fit between the uprights without twisting them. Then place the warp roller between the back uprights C and CX by locating the shaft of the warp roller into the nylon bush in CX. Secure the warp roller by tapping a 5/8 x 75 Steel Shaft through the nylon bush in C and into Z.
18. Fully thread two screw hooks into the brake lever W and one screw hook into the hole underneath FX.
19. Push a M6 x 65 Cup Head Bolt through the castle side EX and tap the head into the wood with a hammer. Place the brake lever W, a M6 X 16 Washer and then a M6 Nylock Nut onto the bolt. Don't overtighten as the brake lever must move freely.

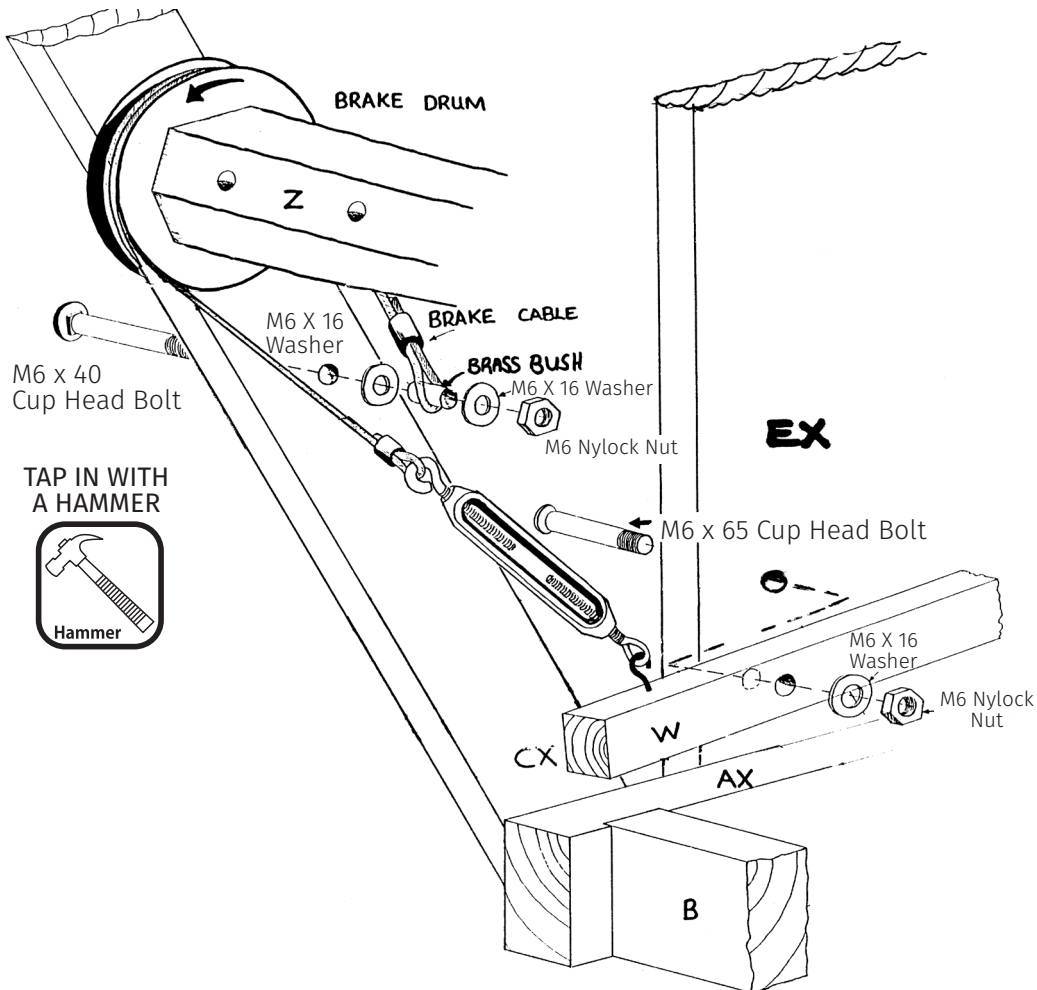
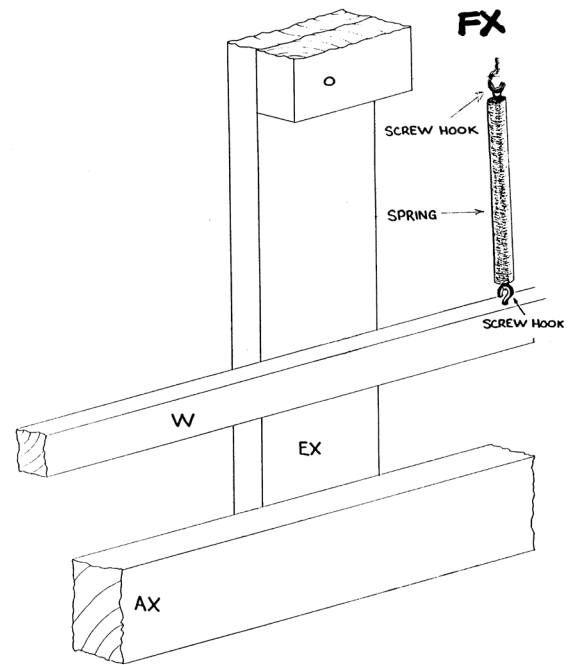

20. Push the M6 x 40 Cup Head Bolt through the upright CX and tap the head into the wood with a hammer. Then locate a M6 x 16 Washer, Brass Spacer M11 x 4, the loop of the brake cable, M6 X 16 Washer and M6 Nylock Nut onto the bolt and tighten firmly. Adjust the screw hooks in the turnbuckle until they are both in the middle of their thread range. Wind the cable around the brake drum 4 times in the direction illustrated starting with the cable closest to the upright CX and attach the turnbuckle to the screw hook at the end of the brake lever W.
21. Locate the spring between the screw hooks in FX and brake lever W.

NOTE: If the brake does not easily release check the following:

 - a) That the wire rope is wound evenly on the brake drum and is not crossed over.
 - b) That the wire cable has been wound in the correct direction.
 - c) Adjust the turnbuckle until the cable grips the brake drum but releases when the brake lever is depressed.

22. Attach the handle to the crank with a M8 x 100 Cup Head Bolt by threading the bolt through the handle and crank. Check the handle spins freely and then lock it with a M8 Hex Nut. Locate crank onto the shaft of warp roller Z and lock in place with 6.3 x 40 Cotter Pin. Spread the ends of the pin slightly to prevent it falling out.

NOTE: The cloth and warp roller must rotate in the direction shown.

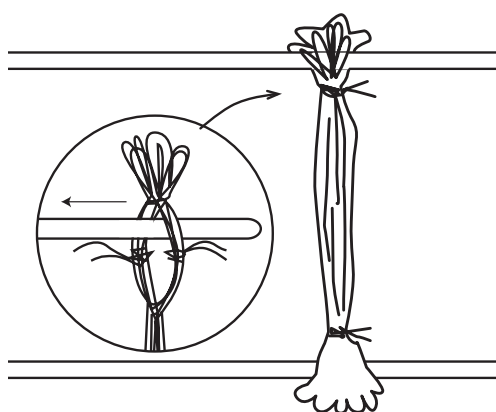
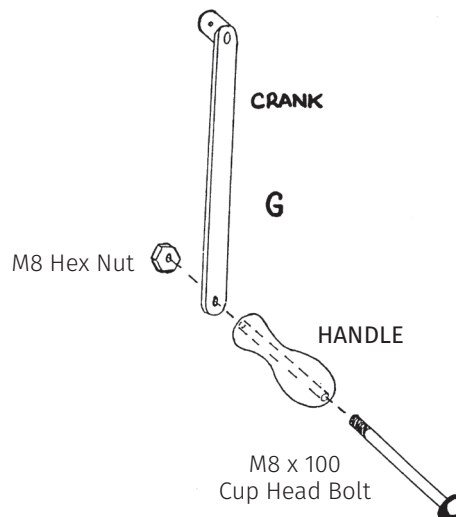
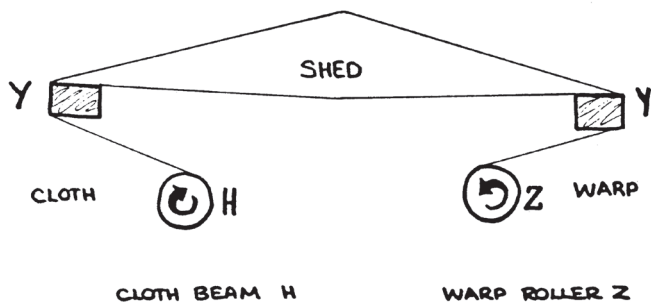

23. Wipe the stainless steel bars with a clean cloth to remove any protective grease. Your Ashford 8 Shaft Jack Loom has been supplied with Texsol Heddles. Each bundle contains 100 heddles which enable you to use 100 per shaft.

Take a bundle of heddles (**DO NOT REMOVE THE PINK TIES**).

Thread 2 round steel bars through the holes in a shafts, through the gaps in the top and bottom of the bundles and into the holes in the other end of the shaft. Then push M11 Rubber Buffers into the oval holes in the outside of the shaft to lock the steel rods in place.

NOTE: Ensure the M11 Rubber Buffers are pushed right to the bottom of the holes so they do not protrude or drag on the nylon guides.

THEN remove the ties and spread the heddles evenly either side of the centre hole.

The heddles can be used as is or can be cut with sharp scissors. Only cut after the heddles have been loaded onto the steel rods.

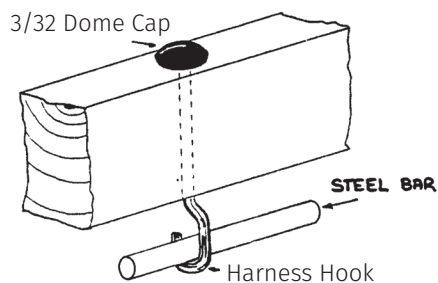

24. Each shaft has holes on both edges of top and bottom rails. The hole for the jack pin is exactly in the centre of the bottom rail to ensure it lifts evenly and is marked with a small hole on the front of the shaft.

Do not use this hole for a hook.

Fit one Harness Hook into the top rail and the bottom rail of each shaft and secure by pressing a 3/32 Dome Cap onto the hook. It is easier to do this by supporting the hook on a corner of a table and pressing firmly on the dome cap. Tap gently with a hammer if necessary.

NOTE: There are 4 spare dome caps for future use. Store them in a safe place.

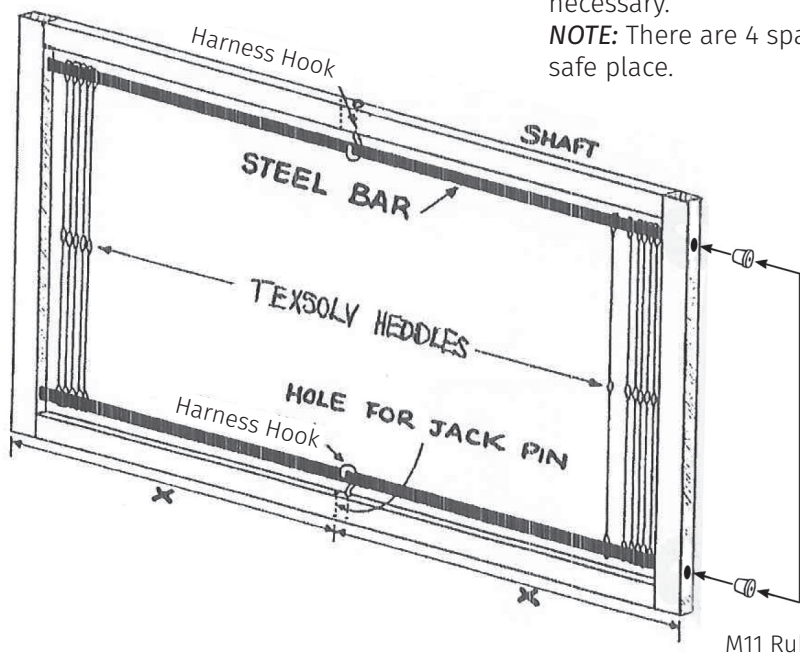

Spread the heddles evenly either side of the Harness Hook and then clip the stainless steel rods over the hooks. The hooks prevent the bars from sagging when being raised or pulling out when the warp is being advanced.

Push M11 Rubber Buffers fully into the holes to keep the steel bars in position.

25. Rub candlewax on the ends of the shafts before loading them into the nylon guides. Load the shafts and locate the jack pin into the centre hole in the shaft. If any of the shafts are curved, to avoid them touching, load them so that the curves are all in the same direction.

26. Attach the castle top rails T to the castle sides E and EX with 8 x 1½ Screws. Locate the shelf V onto the castle. It is easily removable for access to the shafts.

Important: Make sure the ends of the top rails are flush with castle sides. If not the shafts can be tight in the nylon guides.

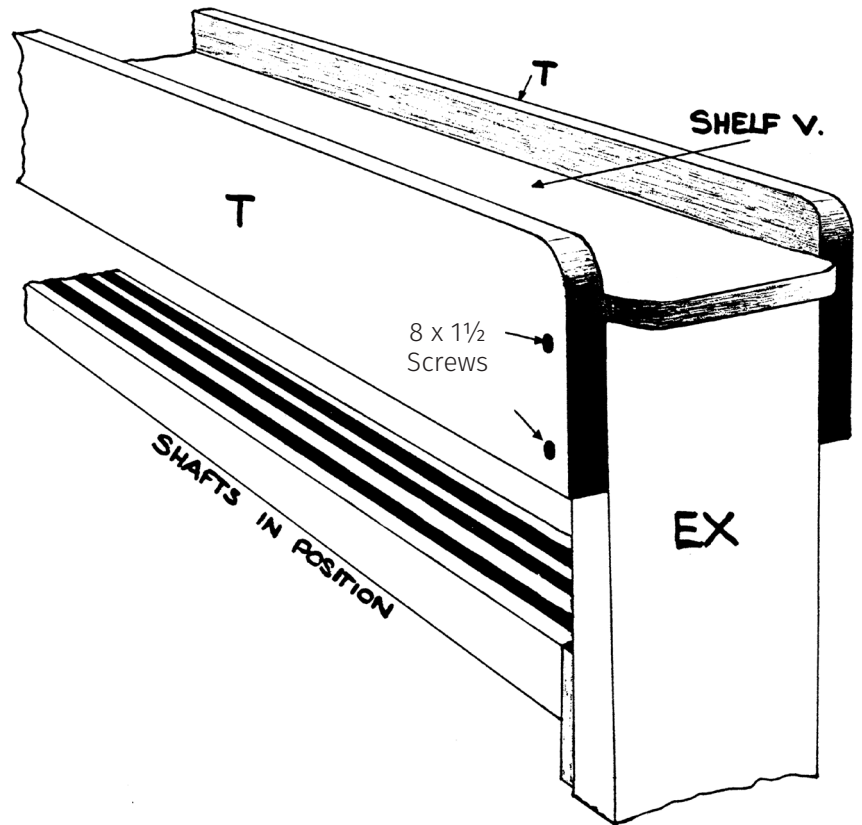

27. Locate the front and back beams Y onto the tenons of uprights C, CX and D, DX. The beams are easily removable to allow access to the shafts when warping.

NOTE: The back beam has a built in raddle with ½" spacing. Fit the beam with the raddle pins facing up when warping, otherwise fit it with the raddle facing down. Use the wooden cover strip to keep your warp in place.

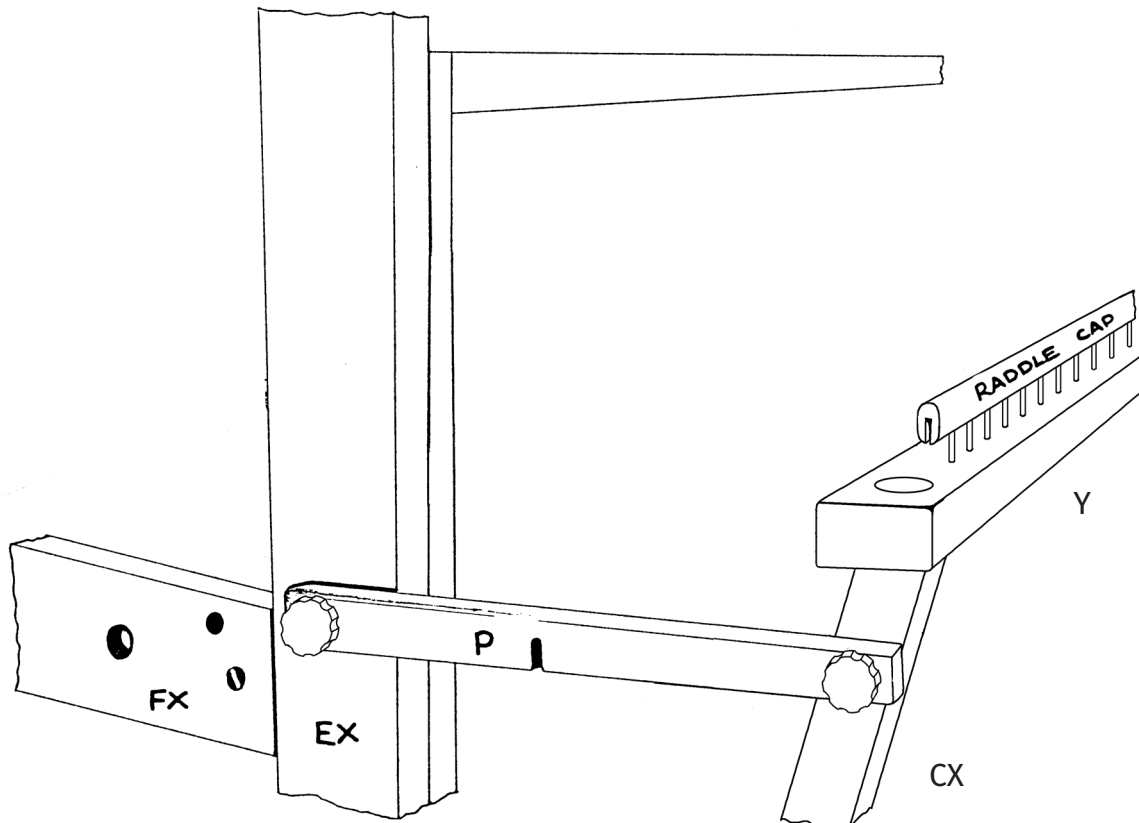

TAP IN WITH A HAMMER

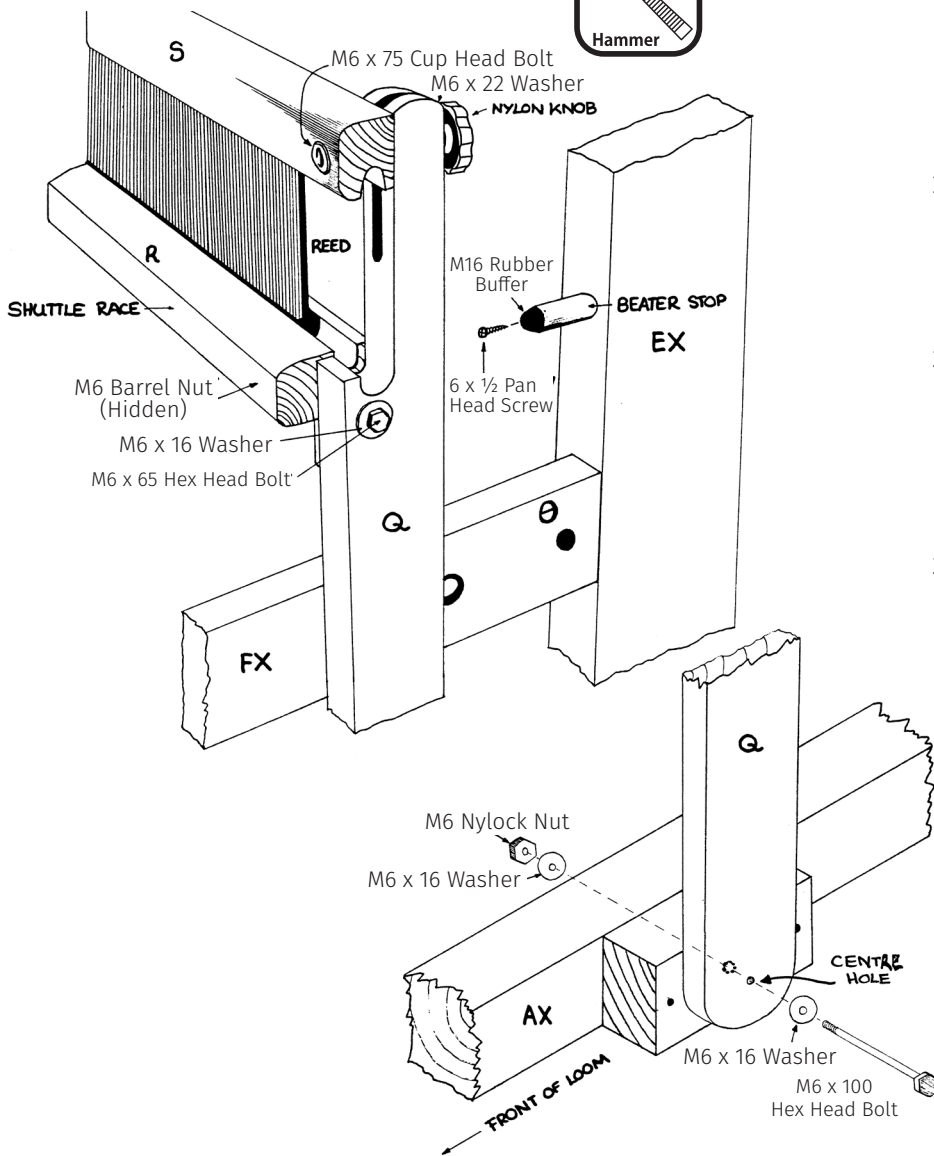

28. Tap the beater stops into the castle sides E and EX. Note the lead holes for the screws face out. Use wood glue if necessary. They should project approx. 70mm (2¾"). Then attach the M16 Rubber Buffer to the stops with 6 x ½ Pan Head Screws.

29. Assemble the beater by joining the sides Q to the bottom rail R with M6 x 65 Hex Head Bolts, M6 X 16 Washers and M6 Barrel Nut. Note the shuttle race faces forward.

30. Place the reed into the groove in the bottom rail R. Secure the top beater rail S to the sides with M6 x 75 Cup Head Bolts, M6 x 22 Washers and nylon knobs. Tap the head of the bolt into the wood with a hammer.

31. Place the beater in position on the loom frame and push a M6 x 100 Hex Head Bolt and M6 X 16 Washer through the beater side Q, through the hole in the spacer block attached to the side A and secure with M6 X 16 Washer and M6 Nylock Nut. Repeat for side AX

NOTE: Do not tighten bolts, the beater must move freely.

32. **NOTE:** There are 8 parallel lams and 10 treadles with 8 holes in each treadle. There are 80 cords, 10 for every lam. Thread all the cords through all the holes in the lams. Then after determining the pattern connect the cord to the hole in the treadle directly beneath it. Do this by feeding a 30cm piece of Texsolv cord through a hole in a lam and loop it through itself. Then feed it down through the corresponding hole in a treadle and secure with a Texsolv peg. **Hint:** It may be more convenient to do this after carefully tipping the loom onto its front.

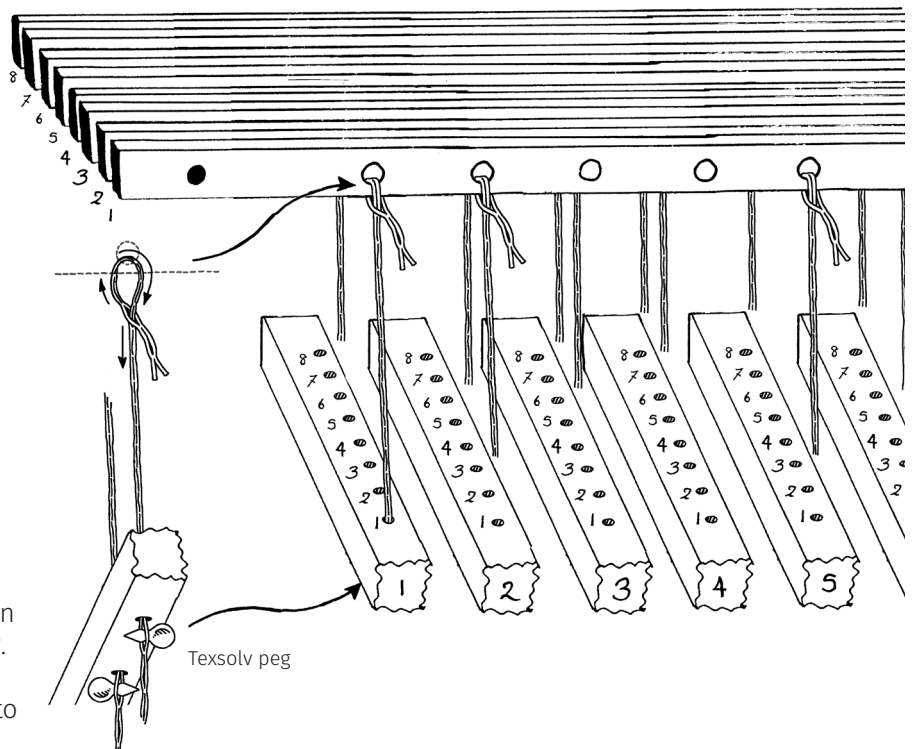

Examples of tie ups

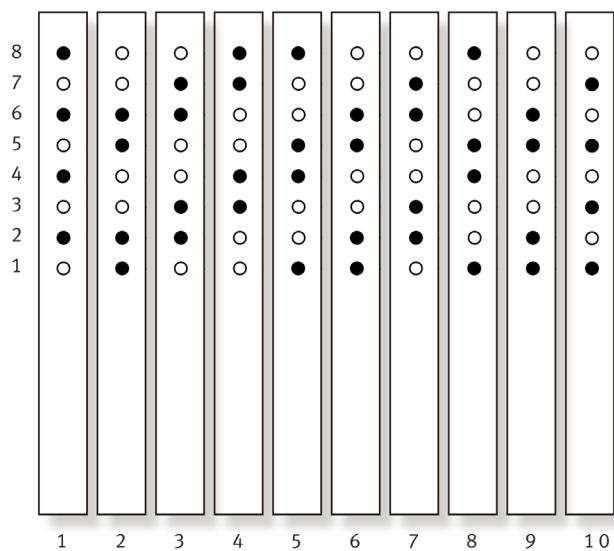

Two x Two Twill with Tabby on treadles 1 and 10

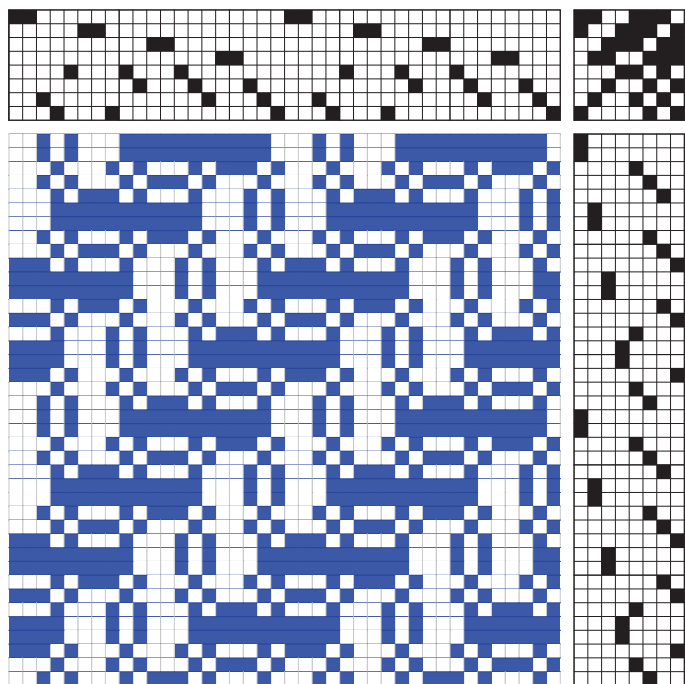

Backed Twill

There are 5 warp sticks included with your Jack Loom.

FRONT ROLLER

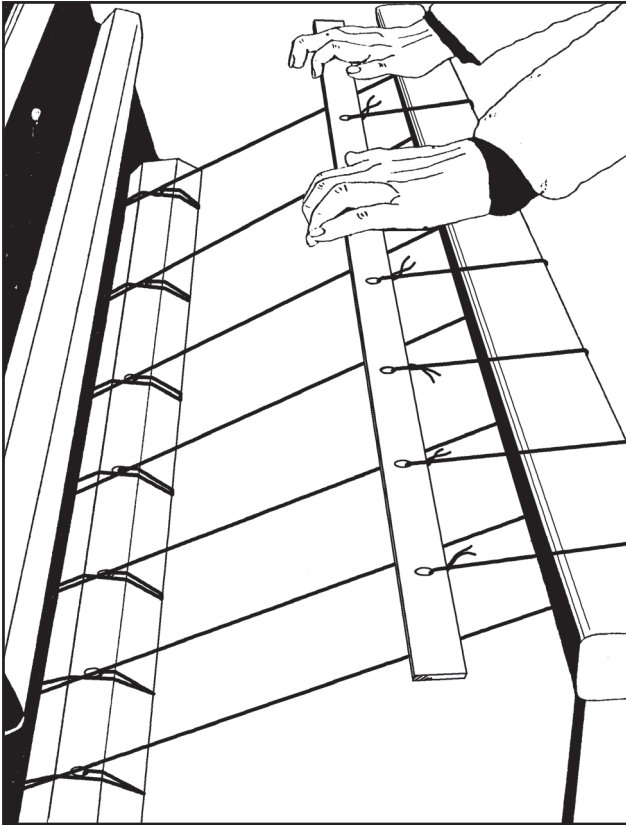

To attach a warp stick to the front roller, thread 1 Texsolv cord through the first hole in the warp stick and back through the second to end hole in the cord.

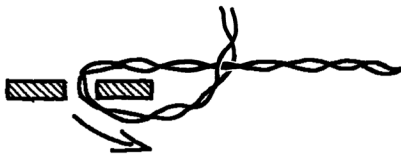

Then take the long end of the cord through the small hole in the warp roller and out the large hole. Then push a Texsolv peg through the cord. The peg pulls down flat into the large hole.

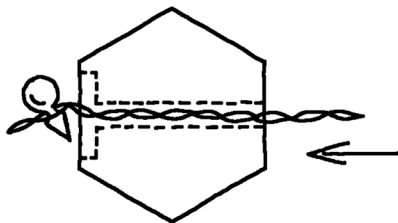

Repeat for all holes.

Warping

For warping instructions please refer to our Jack Loom Warping video on our website www.ashford.co.nz

BACK ROLLER

Thread 1 Texsolv cord through the first hole in the warp stick and back through the 8th hole leaving approx. 10cm of Texsolv cord.

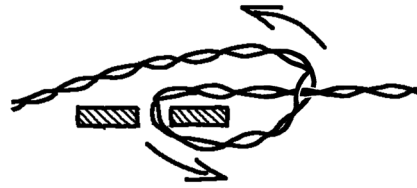

Then take the long end of the cord through the small hole in the warp roller and out the large hole. Then push a texsolv peg through the cord. The peg pulls down flat into the large hole.

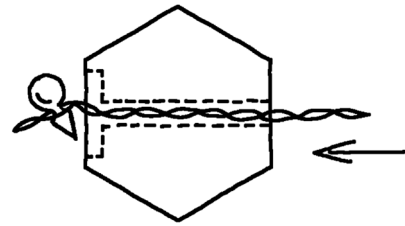

Use the third warp stick for your end warp stick (refer to warp instructions) and attach to the end of the Texsolv cord with a Texsolv peg through the 6th hole.

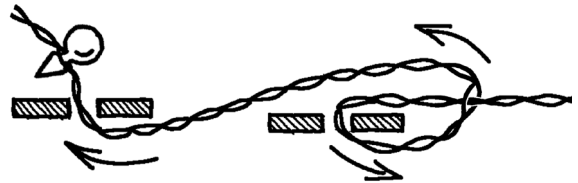

Repeat for all holes.

