

BALL WINDER

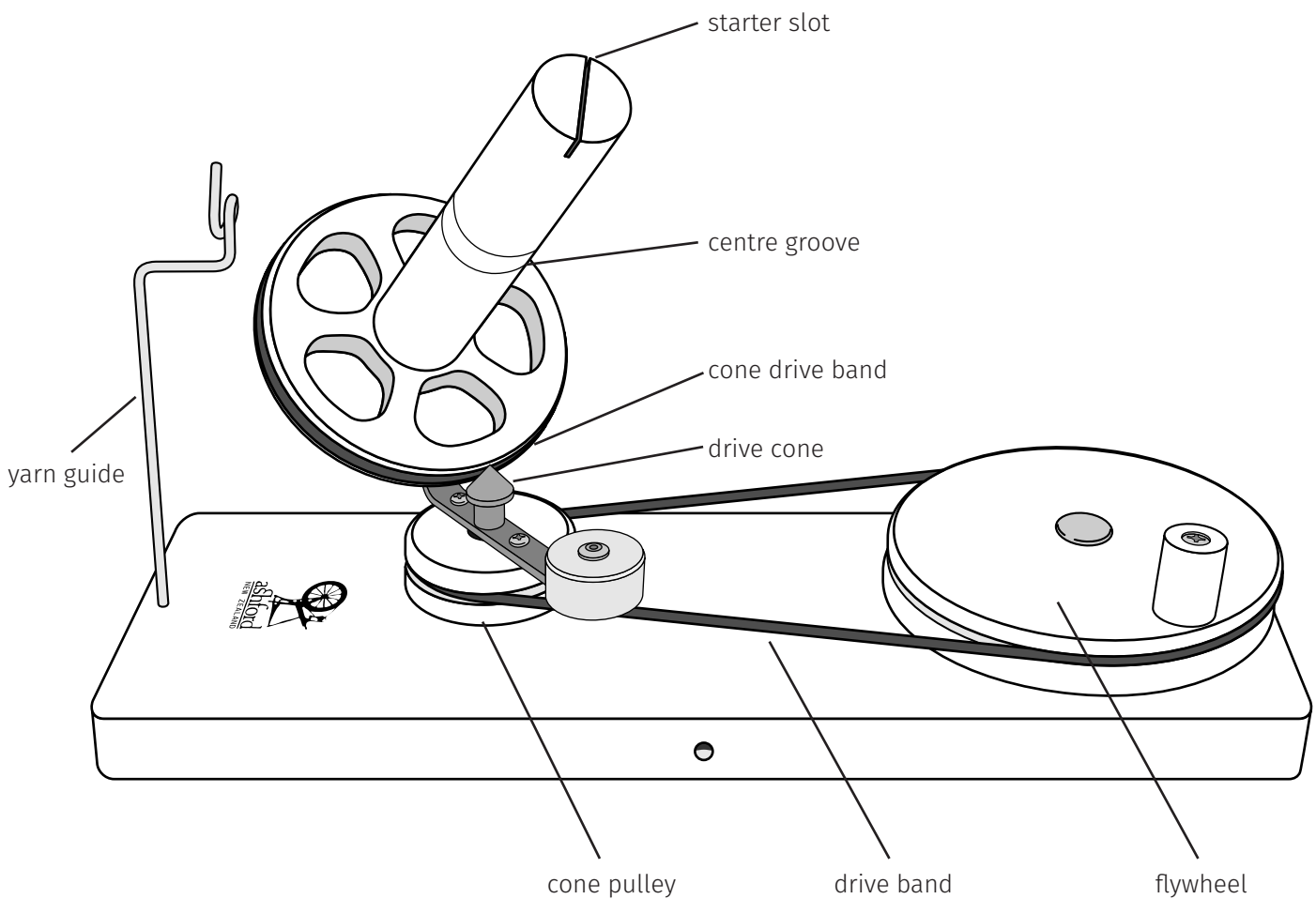

BW090625

INSTRUCTIONS FOR BALL WINDER

Before commencing - please read these instructions completely, identify the parts and note the safe operating procedure.

Finish - your Ball Winder has been lacquered prior to assembly. If desired Ashford Finishing Wax may be applied to further enhance its appearance.

Winding

1. Locate the drive band onto the flywheel and cone pulley.
2. Clamp the Ball Winder to the table.
3. Feed the yarn through the pig tail of the yarn guide.
4. Place the end of your yarn into the starter slot at the top of the cone.
5. Start turning the flywheel slowly in a clockwise direction.
6. Hold the yarn at about a 45-degree angle down from the yarn guide. Encourage the yarn to start forming the ball on the centre groove of the cone.
7. It is very important to keep a constant tension on the yarn with your hand while feeding the yarn onto the same position of the yarn guide.
8. Once the ball has started to form continue to turn the flywheel at a comfortable speed.
9. When winding a large ball, twist the yarn guide out of the way.

IMPORTANT: It is inevitable that the yarn will tangle or snag. Always be ready to stop. Always control the yarn by keeping a constant tension on the yarn. Watch the yarn as it comes off the skeiner and be alert for snags or tangles. If in doubt SLOW DOWN.

How to remove your ball of yarn

Lift the end of the yarn out of the slot in the top of the cone. Use both hands, one either side of the ball of yarn and gently lift the ball off the cone while keeping the end of the yarn free.

Maintenance / Lubrication

- We recommend a drop of Ashford Spinning Wheel Oil be regularly applied to the nylon bearings in the flywheel and cone pulley. **AVOID** getting any oil on the drive cone and the cone drive band.
- When not using your Ball Winder, reduce the tension on the drive band by taking it off the flywheel.
- Replacement drive band sets available separately.

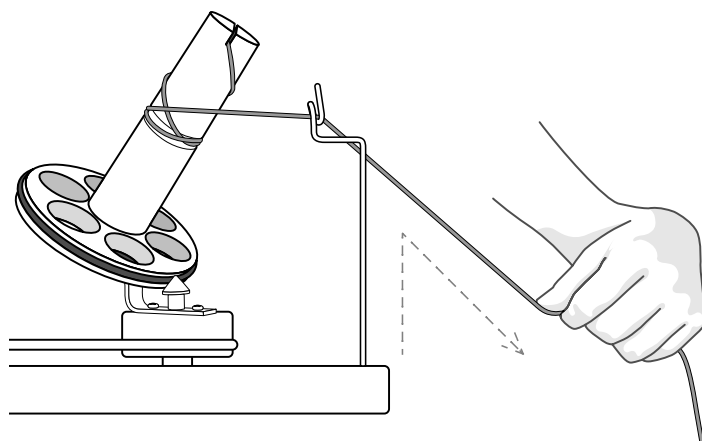
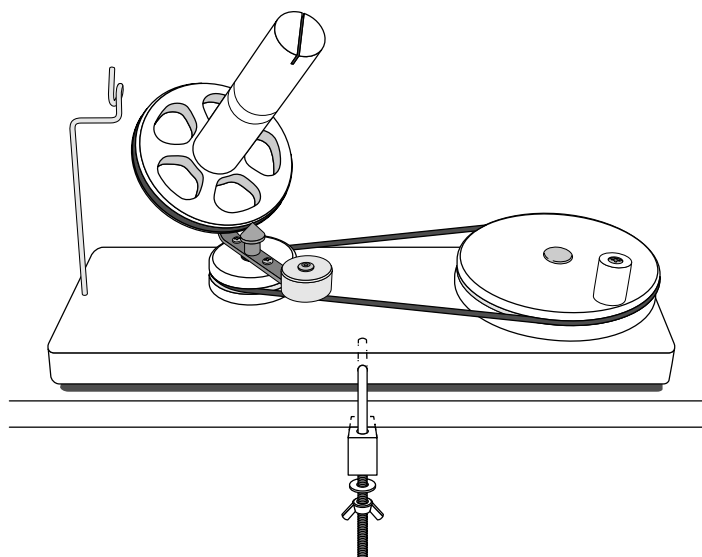

Safe Operating Procedure

Take care to ensure children and pets are always well clear of the Ball Winder while it is in use.

More Information



How-to videos on You Tube

Watch our how-to videos on You Tube.
@AshfordNZ



Facebook

Join us on facebook [ashford.wheels.ooms](https://www.facebook.com/ashford.wheels.ooms)



Blog

For inspirational articles, patterns and projects. Subscribe for free to the Ashford Blog
www.ashford.co.nz/blog