

JOY 2 SPINNING WHEEL SINGLE & DOUBLE TREADLE WITH A SLIDING HOOK FLYER

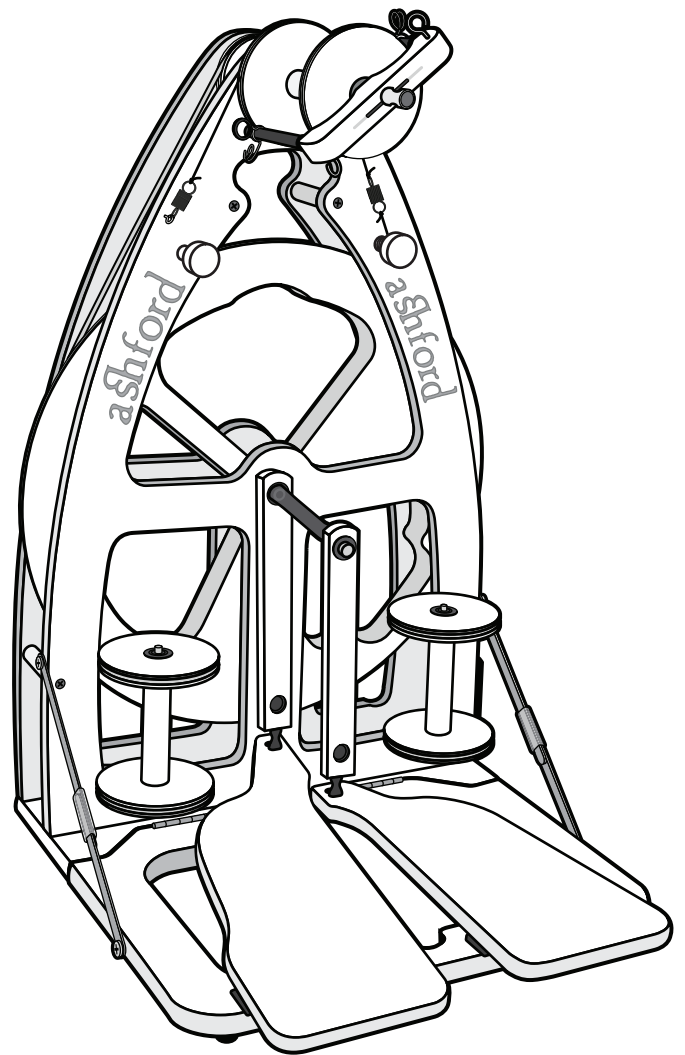
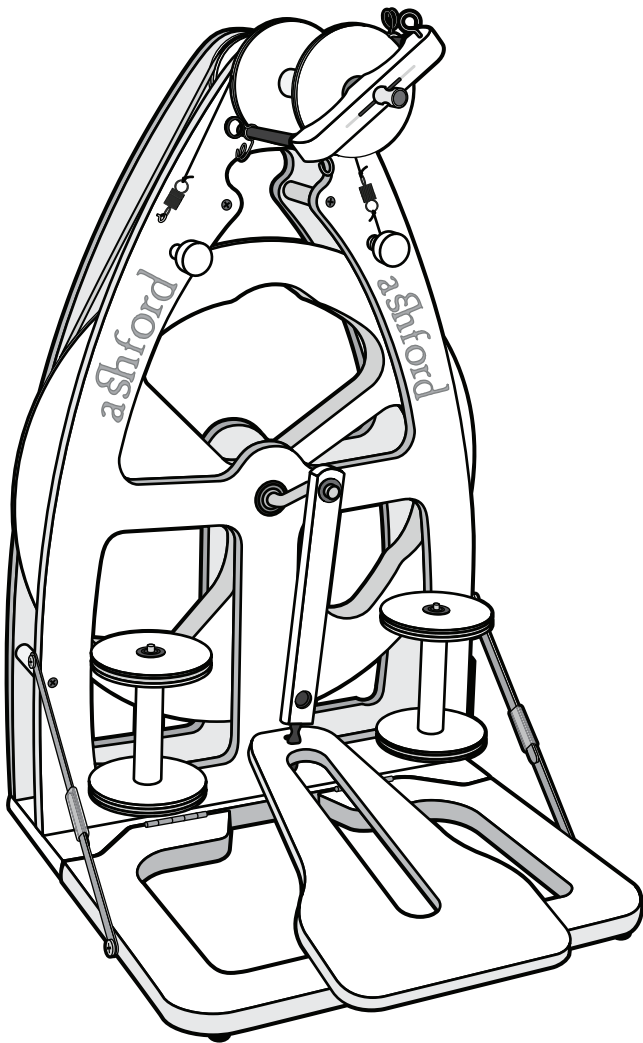

JASW080920V10

ASSEMBLY INSTRUCTIONS FOR JOY 2 SPINNING WHEEL SINGLE & DOUBLE TREADLE WITH A SLIDING HOOK FLYER

Your Joy 2 spinning wheel has been lacquered prior to assembly. If desired, the application of Ashford Wax Finish may further enhance its appearance.

Parts

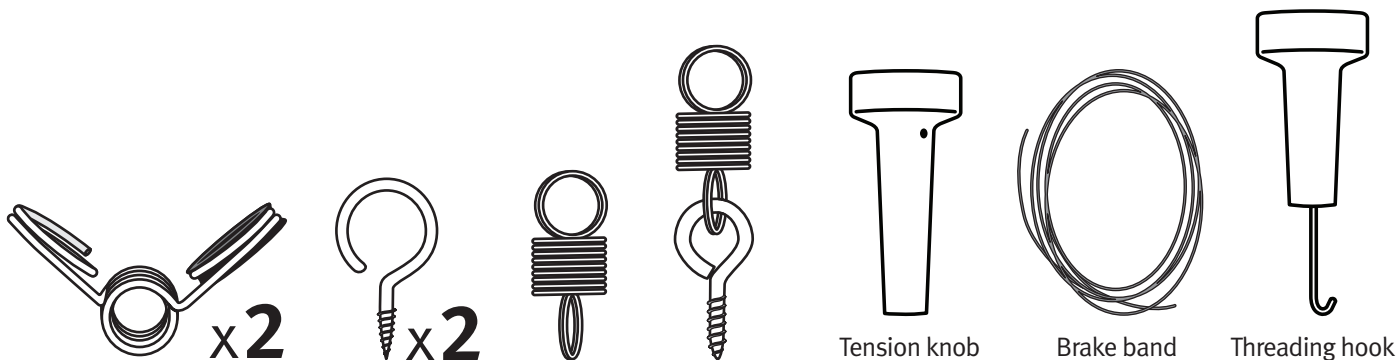

1

Disengage the latch.

Note: The screw on the treadle board has been tightened for shipping.

Loosen the screw, fold the treadle board down and lock the metal stays into position.

Slide the clear sleeves over the joint to secure the metal stays.

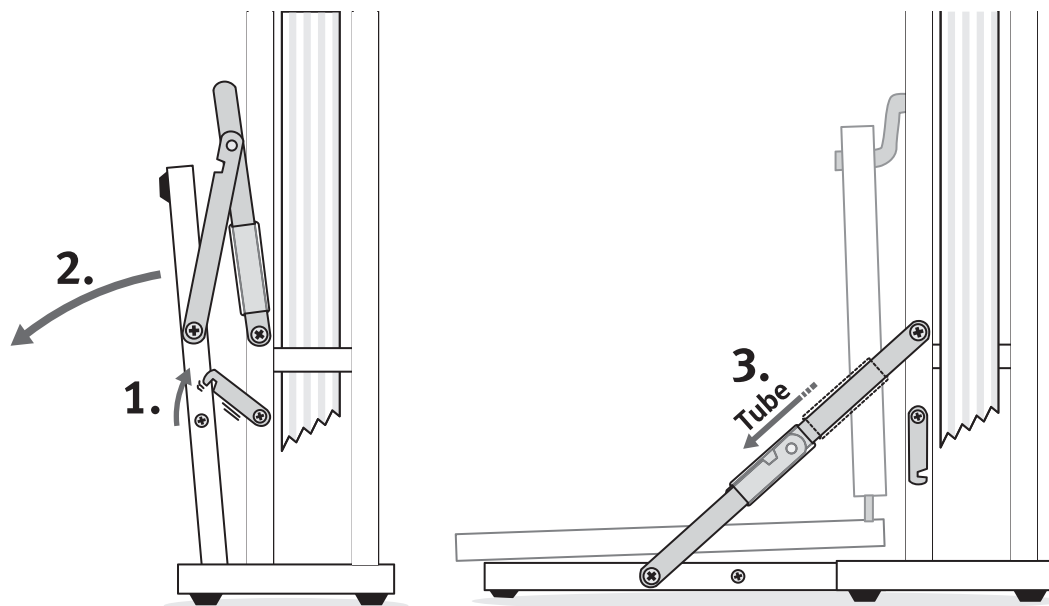

2

Thread the 2 hooks into the pilot holes in the flyer base. Squeeze and slide the stainless steel yarn guides onto the flyer arms.

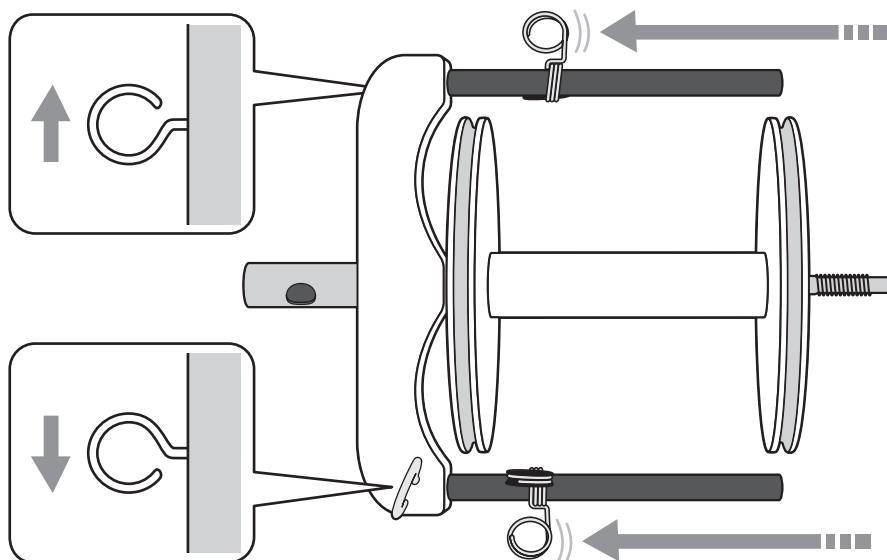
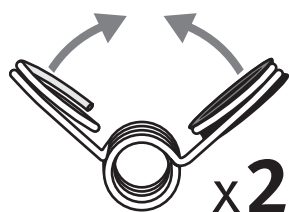

3

Cut 40cm (16in) off the brake band. Tie one end to the spring attached to the screw eye and the other to the second spring so that you have 27cm (10³/₄in) between the 2 springs (See side of this page). Tie one end of the surplus nylon to the second spring, and thread the other end through the tension knob and tie a knot. Trim off surplus nylon.

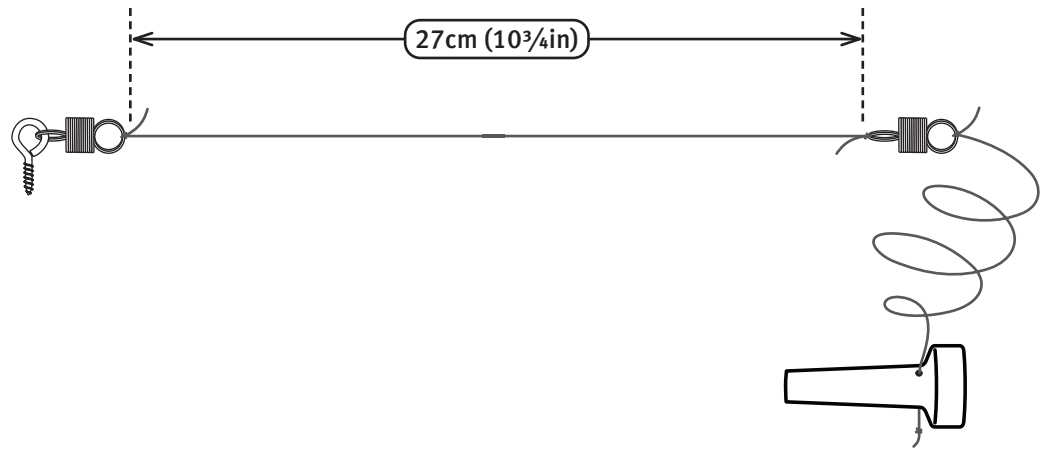

4

Thread the screw eye with the brake band spring attached into the hole in the front frame.

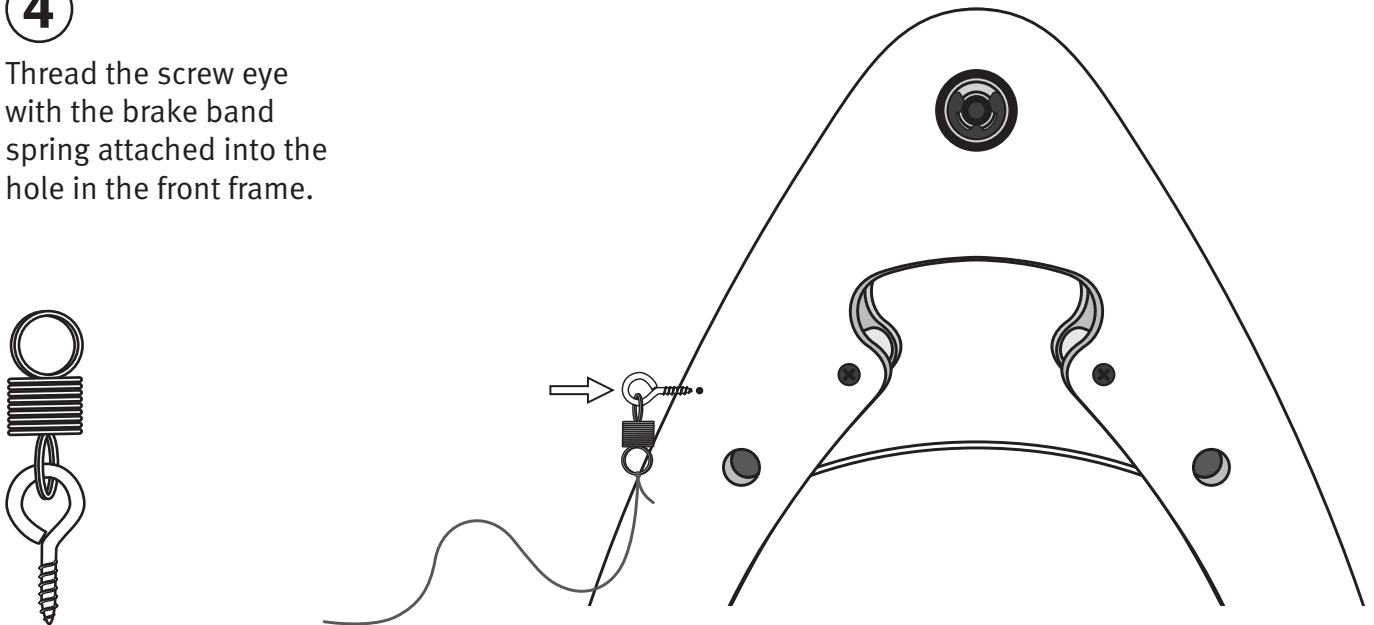

5



Apply a drop of oil to the flyer spindle and slide the bobbin on. Ashford spinning oil is ideal for this purpose. Thread the flyer spindle into the top shaft. Hold the flyer whorl with one hand and rotate the flyer clockwise with the other. Tighten firmly.

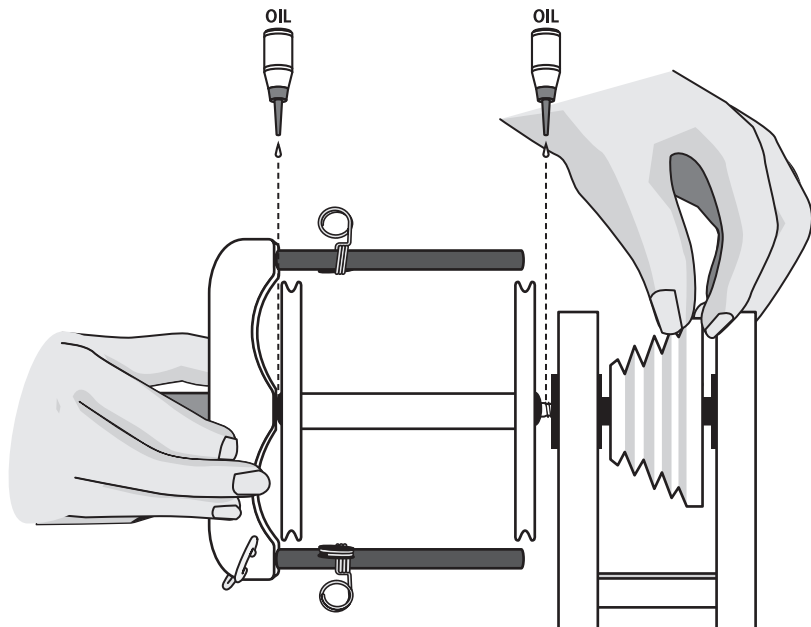

6

Insert the tapered tension knob and threading hook into the holes in the front. Place the brake band into the groove in the bobbin and adjust the tension knob so the

knob so the springs only just begin to stretch.

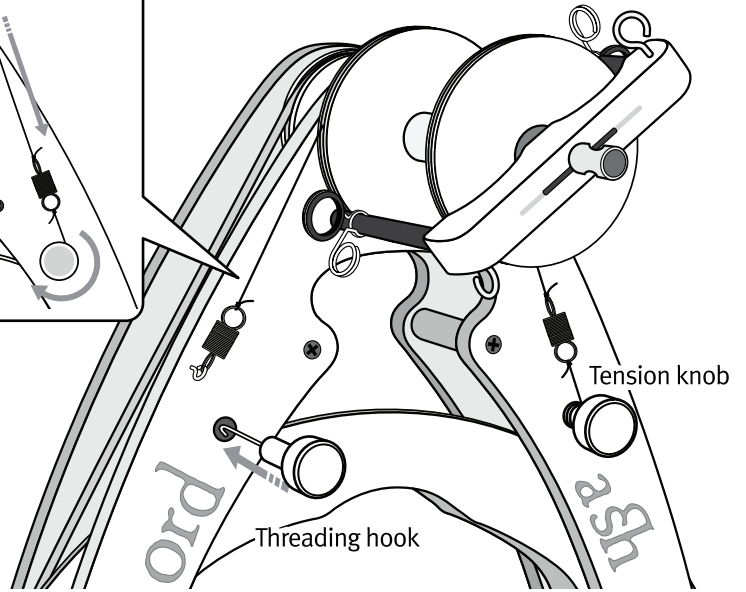
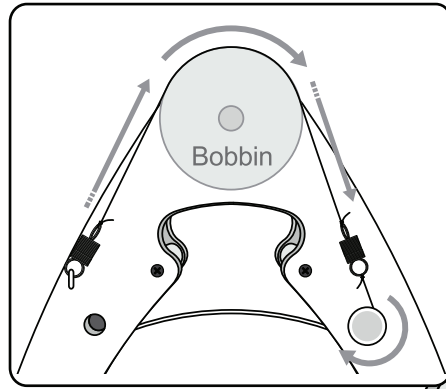
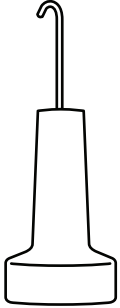

7

Locate the two spare bobbins onto the bobbin holders in the front frame. When plying or spinning bring the bobbins forward. Push them back before folding the treadle up.

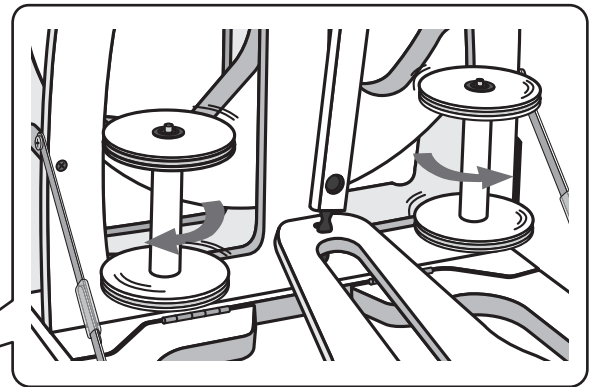
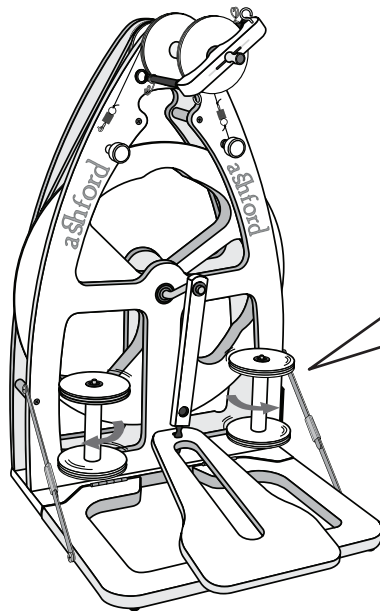

8



To make spinning easier apply a drop of Ashford

Spinning Wheel Oil to the flyer, bobbin and conrod bearings. Note: The ball bearings are sealed for life and **do not** require oiling.

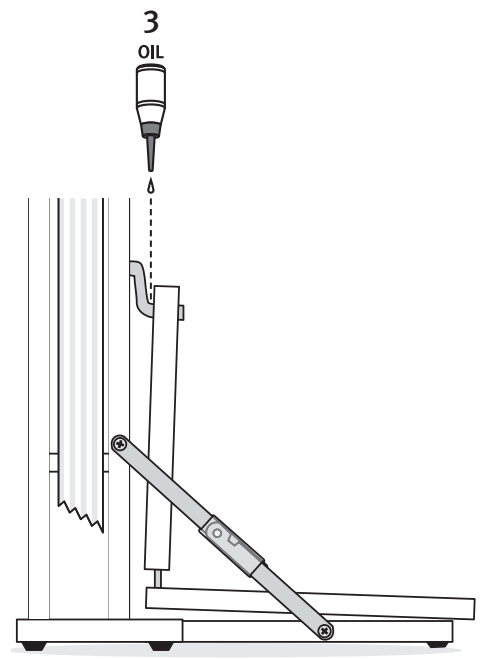
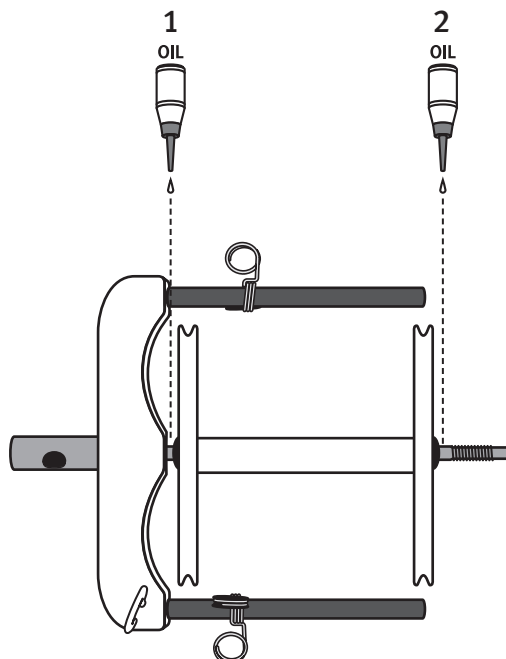

Ratio

Position the stretchy drive cord around the smallest groove in the wheel and then over the largest flyer whorl. This gives a flyer to wheel ratio of 6:1. The other ratios are 8, 11 & 14:1. When changing ratios ensure the drive cord directly aligns the wheel and flyer whorl. When spinning coarse fibres or thick yarns use the slowest flyer speed of 6:1. For fine fibres and yarns use a higher ratio.

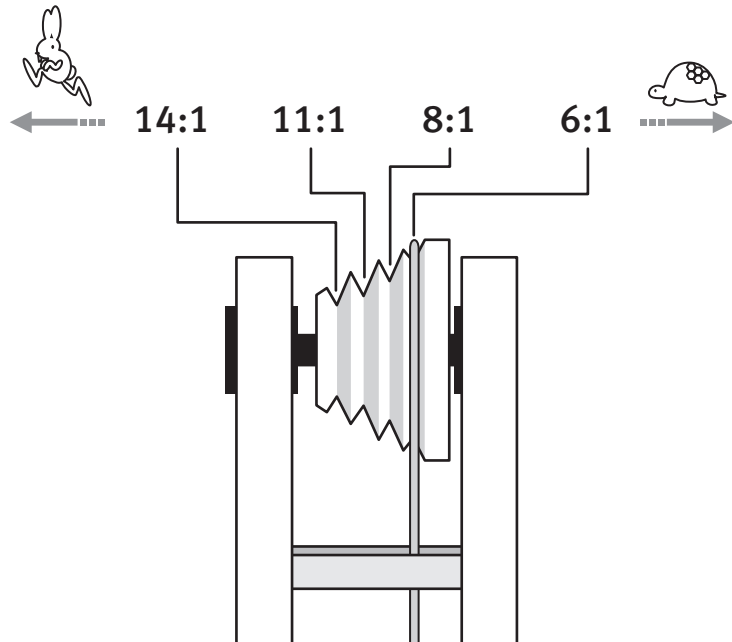

Folding up your Spinning Wheel

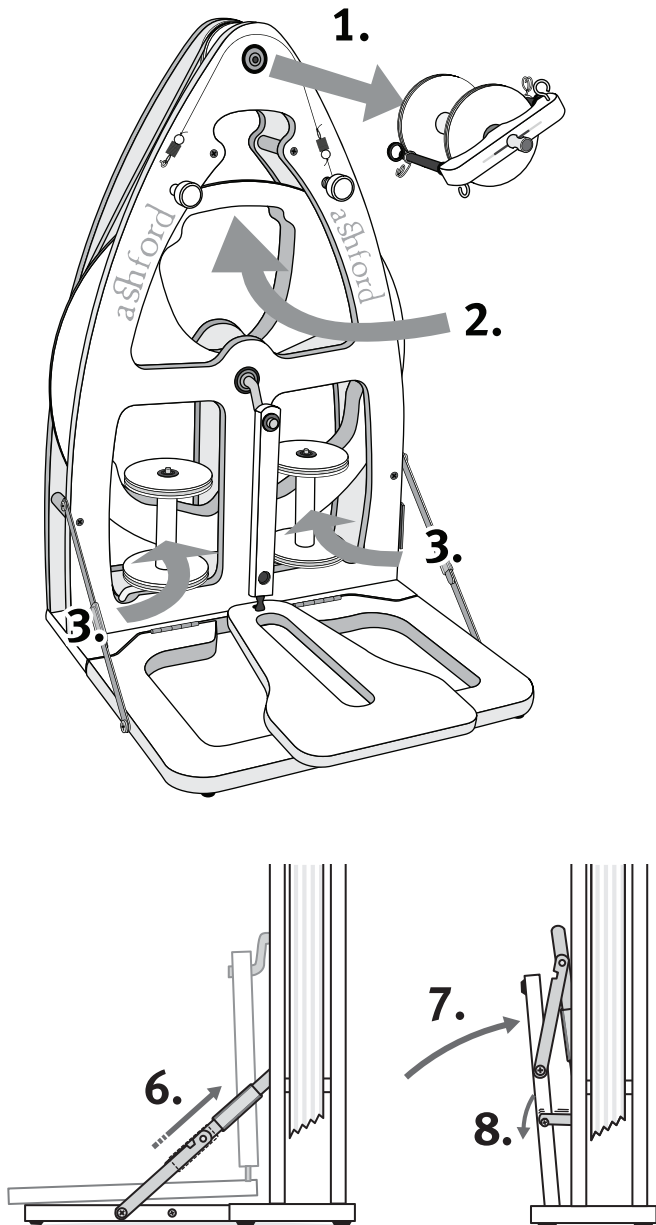

4. Double treadle only

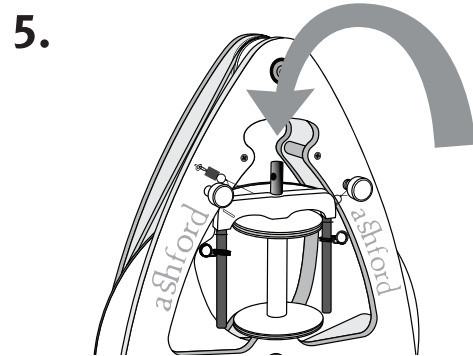
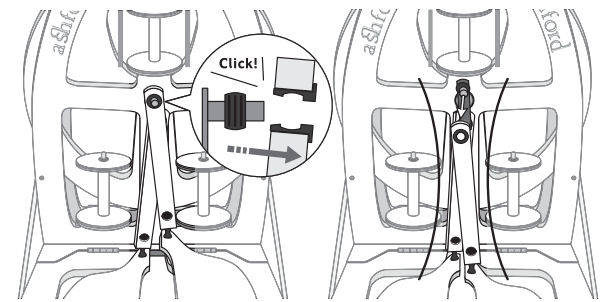

9. Always carry it by the built in handle or in the optional carry bag. Do not carry it by the flyer which could bend if handled roughly.

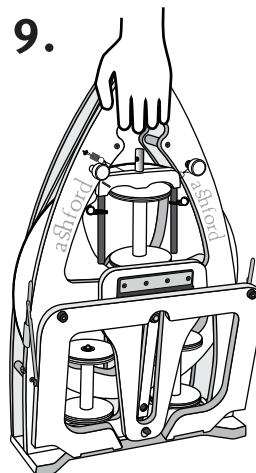

You are now ready to start spinning

Step 1

Tie a piece of yarn called a leader, approx. 1m (1yd) long, on to the bobbin. Thread it through the yarn guide, around the flyer hook on the **right-hand side of the flyer** and out through the orifice.

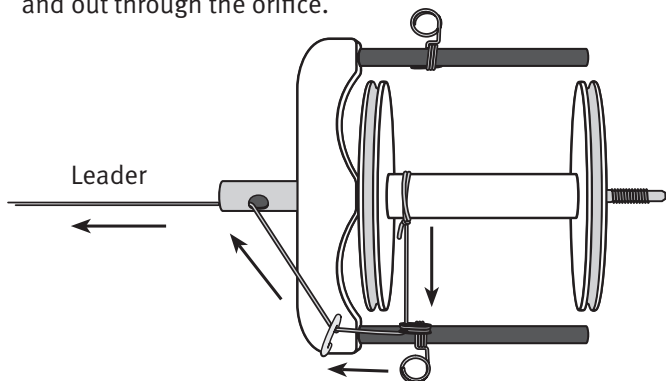

Step 2

Adjust the tension knob so that the brake band springs are only just starting to extend. Too much tension will make treading harder.

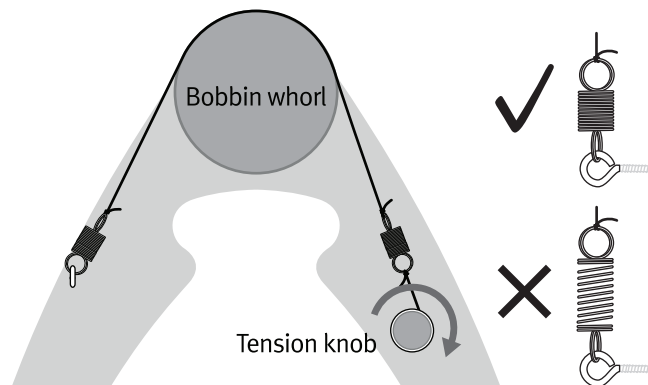

Step 3

Sit in a comfortable position. A straight back Ashford Spinning Chair is ideal. On the single treadle Joy 2, treadle with either foot or both together.

Step 4

The wheel is weighted so the crank will always come to rest in the 1 o'clock position. To start spinning just push down with your foot. Practice treading slowly clockwise.

Step 5

Join your prepared fibres onto the leader. Now you are spinning singles. Treadle slowly.



Step 6

To ply two singles together, place two bobbins of single ply yarn on the two bobbin storage pins. Tie these two yarns onto the leader. Treadle the wheel anticlockwise.

For further spinning information refer to "The Ashford Book of Hand Spinning", a 116 page book full of ideas and inspirations for spinners.

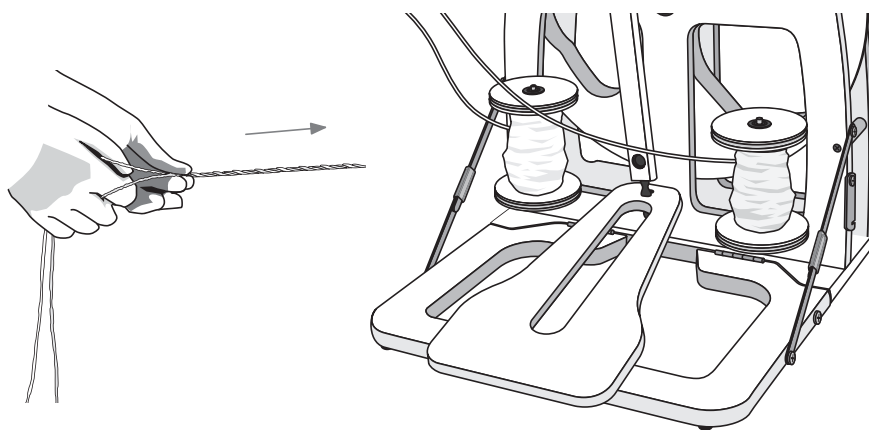

Maintenance

Replacing a broken or worn drive belt

1. Take these 10 screws out.

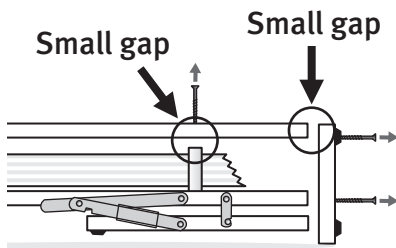
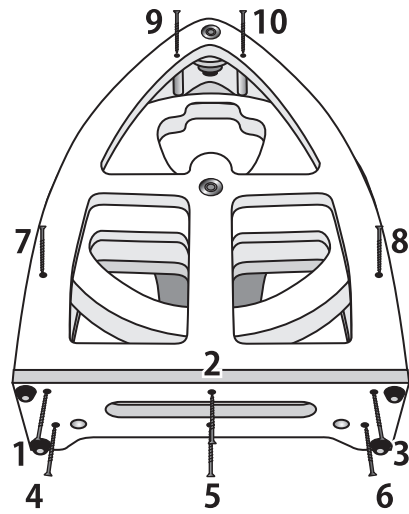

2. Slide new band in place.

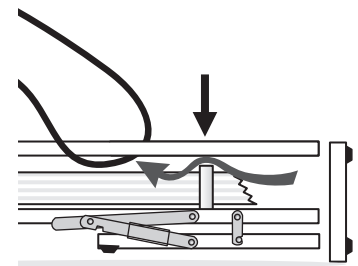
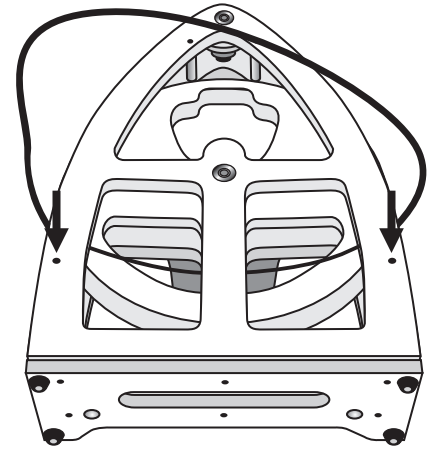
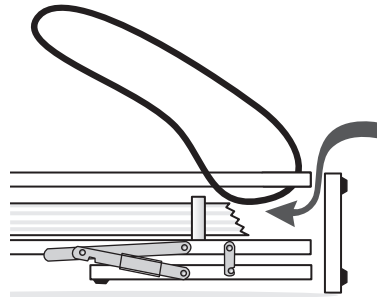
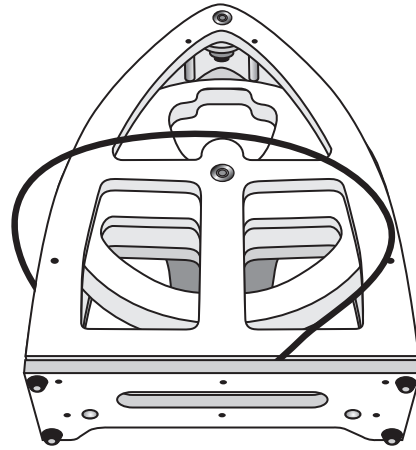

↳ Tighten all screws.

Memo

How to insert the polyurethane conrod joints into the conrod.

*This has been pre-assembled in the factory.

1.

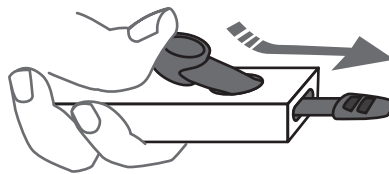

2.

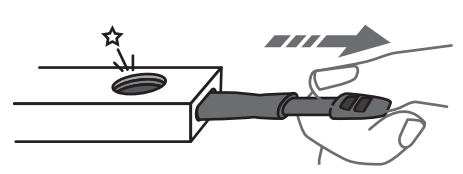

More Information



How-to videos on You Tube

Watch our how-to videos on You Tube.
www.youtube.com/user/AshfordHandicrafts



Facebook

Join us on facebook.
www.facebook.com/ashford.wheels.ooms



The Wheel Magazine

Ashford's annual fibrecraft magazine. Spinning, weaving, felting, dyeing and knitting projects, patterns and articles from around the world. To receive the glossy version delivered to you, subscribe at:
www.ashford.co.nz/subscribe