

## ASHFORD HOBBY BENCH

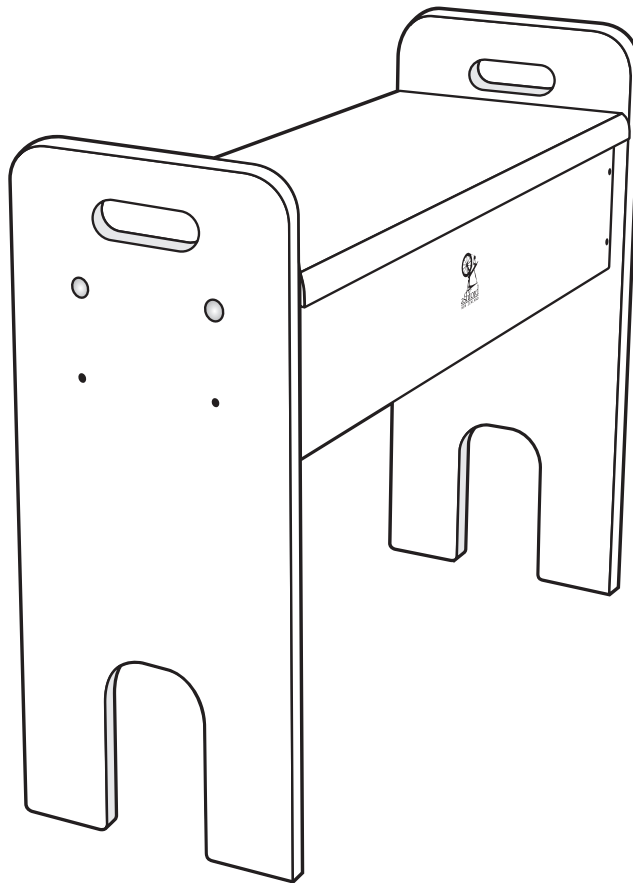

### TOOLS REQUIRED

Screwdriver, candlewax (for wood screws) and damp cloth for wiping off excess glue.

### BEFORE COMMENCING

Read instructions completely, identify the parts and note the assemble sequence.

### FINISHING THE WOOD

We recommend the kiln dried silver beech timber be first sanded smooth and the corners removed using the enclosed sandpaper then sealed before assembly. This protects it from climatic changes and enhances its character and beauty. Our natural Ashford Wax Finish is ideal for this purpose.

**STEP 1:** Attach the hinges to the underside of the seat with the small wood screws.

**STEP 2:** Attach the two tray ends to the front with

long screws. Position the tray bottom into the groove in the front best side up and then attach the back also with long screws. Please use glue in these joints.

**STEP 3:** Attach the bench legs to the tray frame with two bolts, use a hammer to tap the bolts in flush, attach washers and wing nuts to the inside. The bench height may be raised or lowered by selecting any of the 4 height positions. Ensure wing nuts are fully tightened before using the bench.

**STEP 4:** Secure the seat to the tray by attaching the hinges to the back with small screws. Care should be taken not to slam the seat back as hinge screws may weaken.

**STEP 5:** Locate the small division spaces in the slots in the tray. Your Hobby Bench is now ready for use.

HB15062017V5

### Ashford Guarantee

Thank you for purchasing this Ashford product. In the unlikely event there is any fault in manufacture, please contact the dealer you purchased it from. To validate the guarantee, please go to [www.ashford.co.nz/product-registration](http://www.ashford.co.nz/product-registration)