

KIWI SLIDING HOOK FLYER - Single Drive -

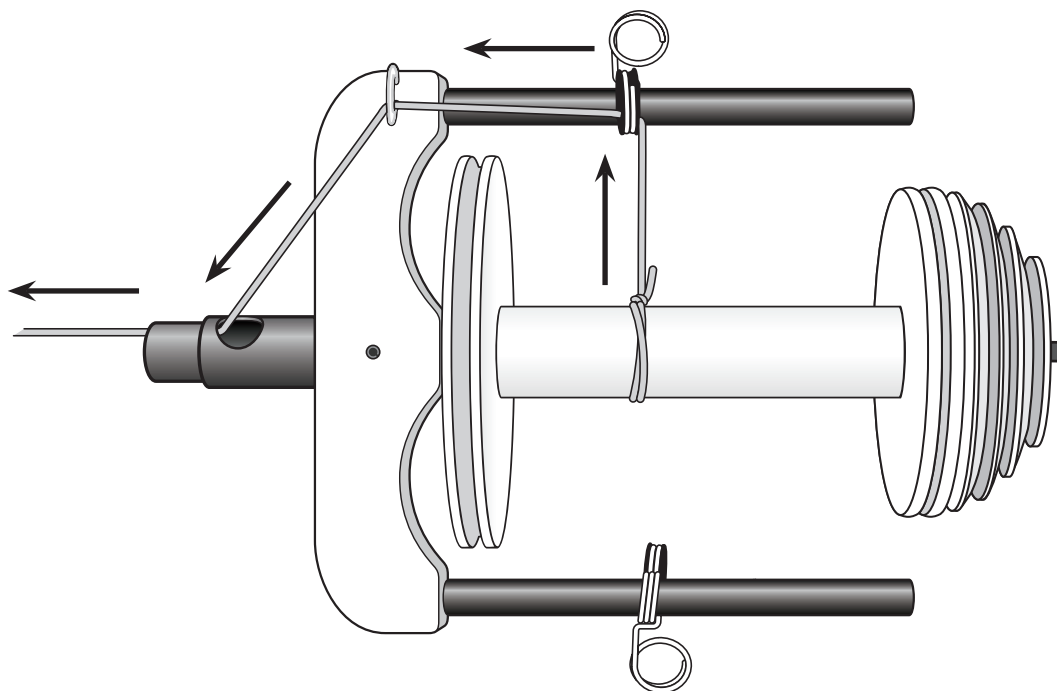

FEATURES

- Flyer comes with one single drive bobbin.
- Fill your bobbins evenly with the squeeze and slide stainless steel yarn guides.
- Fibreglass arms result in a light and strong flyer.
- The 3 speed pulley allows a wide range of yarns to be spun.

Ratios

5 7.5 9.5 :1

Wood finish

We recommend the wood be sealed with a wax or oil finish before use to protect and enhance it's natural beauty. Ashford finishing wax polish is ideal for this purpose.

1. Screw the 2 hooks into the pilot holes in the flyer base.
2. Squeeze and slide the stainless steel yarn guides onto the flyer arms.
3. Apply a drop of oil to the flyer shaft and slide the bobbin on. Ashford spinning wheel oil is ideal for this purpose.
4. Partially locate the whorl onto the flyer shaft and rotate the whorl until the flat spot on the flyer shaft aligns with the flat spot in the whorl. Then push the whorl on.

Caution: Do not twist the whorl, only slide the whorl on or

off. If it is tight apply a drop of oil to the end of the flyer shaft.

To change the bobbin, grip the whorl with one hand and the flyer with the other and slide the whorl directly off.

5. Locate the pin on the end of the flyer whorl into the back bearing and "click" the orifice end of the flyer into the front bearing. A drop of oil occasionally on the flyer and bobbin bearings will make treadling easier and reduce noise.
6. Position the brake band over the bobbin and hook the spring to the cup hook. Turn the tension knob until the tension springs just starts to stretch. When spinning the springs should not stretch more than their own length.
7. Attach the threading hook to your spinning wheel with the cotton tape.
8. Tie a leader yarn approx. 1.5m (5ft) to the bobbin centre and feed it through the yarn guide, around the flyer hook and through the orifice.
9. As your bobbin fills, squeeze and slide the yarn guides to fill your bobbin evenly. When not using your Kiwi release the tension on the drive belt by taking it off the flyer whorl.

Happy Spinning!

KSHF130224

Ashford Guarantee

Thank you for purchasing this Ashford product. In the unlikely event of a fault in manufacture, please contact the dealer you purchased it from.

Ashford Blog

For inspirational articles, patterns and projects. Subscribe for free www.ashford.co.nz/blog